

TruRyde®

Powered by **DEEMAXX**

Disc Brakes

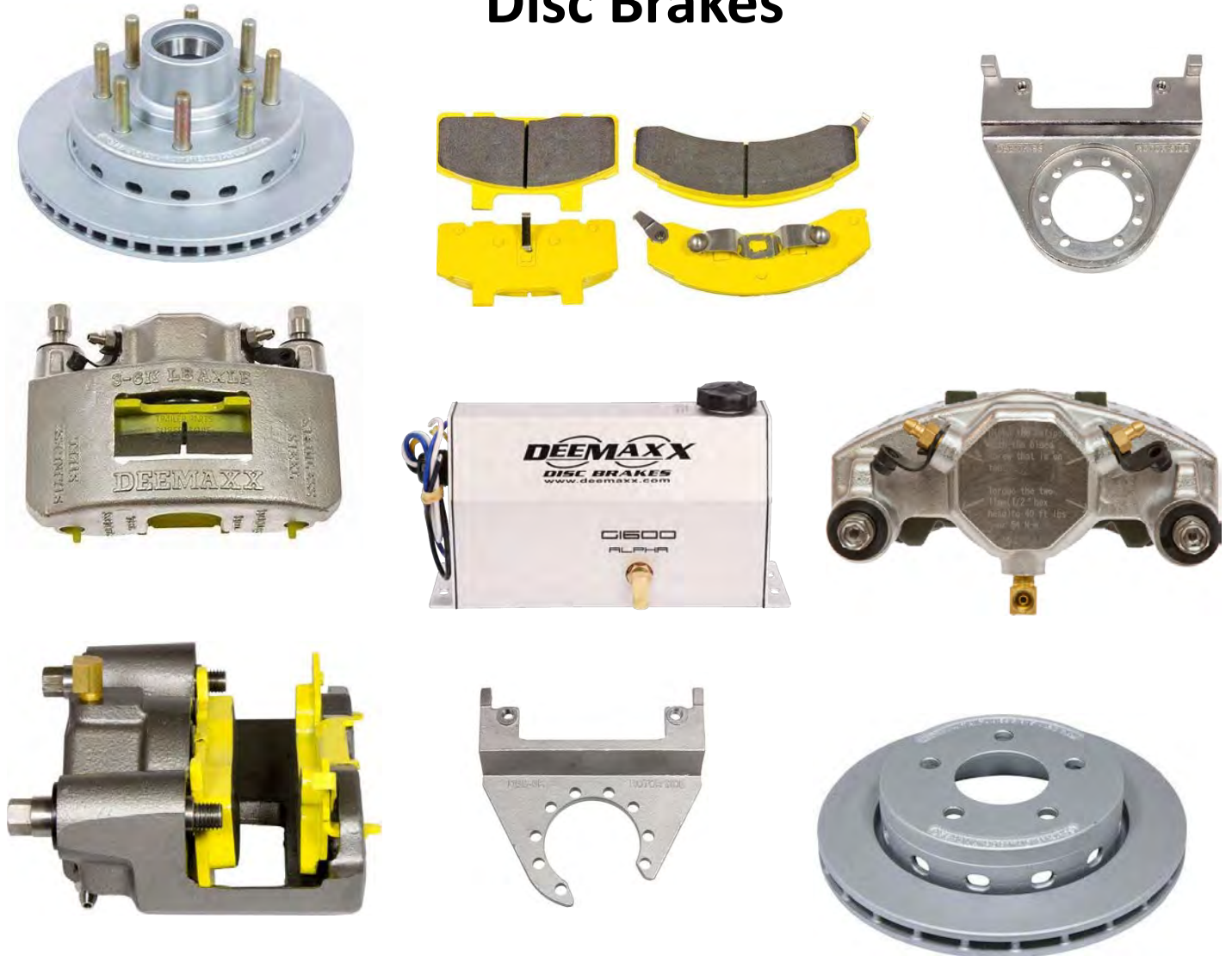

SUPPLYING THE WORLD.



To learn more about our complete line of axle and suspension components

Visit us at www.trpintl.com

Email us at trpintl@trpintl.com

972.279.9863 Dallas

574.389.9941 Elkhart

3.5K

5 lug 1/2" studs

Rotor:

Integrated or Slip Over

Finish:

MAXX or GOLD

Integrated Kit Includes (2) DEEMAXX 10" Integral 5-Lug Vented Rotors, (2) Calipers, (2) Mounting Brackets and (4) Caliper Pads.

Slip Over Kit Includes (2) DEEMAXX 10" 5-Lug Vented Rotors, (2) Calipers, (2) Mounting Brackets and (4) Caliper Pads.

One kit required per axle.



DBI-3.5K-MAXX



DBSO-3.5K-MAXX

6K

6 lug 1/2" studs

Rotor:

Integrated or Slip Over

Finish:

MAXX or GOLD

Integrated Kit Includes (2) DEEMAXX 12" Integral 6-Lug Vented Rotors, (2) Calipers, (2) Mounting Brackets and (4) Caliper Pads

Slip Over Kit Includes (2) DEEMAXX 12" 6-Lug Vented Rotors, (2) Calipers, (2) Mounting Brackets and (4) Caliper Pads.

One kit required per axle.



DBI-6K-MAXX



DBSO-6K-MAXX

7K

8 lug 1/2" studs

Rotor:

Integrated or Slip Over

Finish:

MAXX or GOLD

Integrated Kit Includes (2) DEEMAXX 13.1" Integral 8 Lug Vented Rotors, (2) Calipers, (2) Mounting Brackets and (4) Caliper Pads.

Slip Over Kit Includes (2) DEEMAXX 13.1" 8 Lug Vented Rotors, (2) Calipers, (2) Mounting Brackets and (4) Caliper Pads.

One kit required per axle.



DBI-7K-MAXX



DBSO-7K-MAXX

8K:

8 Lug

Rotor:

Integrated -9/16" studs

Integrated -5/8" studs

Slip Over

Finish:

MAXX or GOLD

Integrated Kit Includes

- (2) DEEMAXX 13.1" Integral 8-Lug Vented Rotors
- (2) Calipers
- (2) Mounting Brackets
- (4) Caliper Pads

One kit required per axle.

Slip Over Kit Includes

- (2) DEEMAXX 13.1" 8-Lug Vented Rotors
- (2) Calipers
- (2) Mounting Brackets
- (4) Caliper Pads

One kit required per axle.

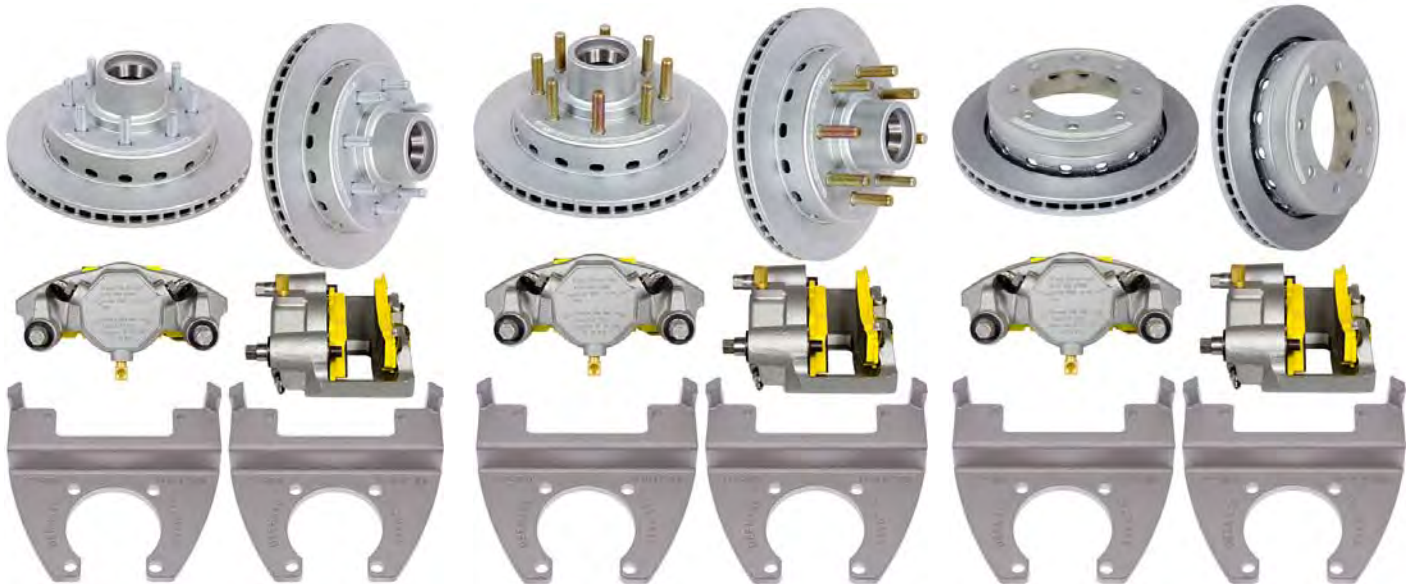

DBI-8KD9-MAXX

NOT PICTURED: DBI-8KA9-MAXX *DBB-8KA-MAXX

DBI-8KD10-MAXX

DBSO-8KDD-MAXX

****Also Available****

10K—12K Single Wheel and 10K—16K Dual Wheel

Contact your TRP representative

Exclusive Advantages -

- *Exclusive reverse mount slip over rotor means cooler running, better plating, and no more premature corrosion!
- *Unique rotor cross section design actively draws cooling air from the rotor interior!
- *Exclusive 120° bleeder design means better bleeding, balanced system, and no more damaged bleeders!
- *Exclusive laser writing on caliper means instructions are always there!
- *Every caliper is tested to 2000psi!
- *Robust ductile iron casting eliminates flexing resulting in more brake torque!
- *Exclusive bolt design means no more mishandling or incorrect shipping of bolts!
- *Compatible with every surge and electric over hydraulic actuators!
- *Ceramic brake pads are slotted, chamfered, and feature a stainless steel clip!
- *Unique bracket design provides twice as many mounting options for caliper position!
- *Produced in ISO QUALITY certified factories!
- *PASSED THE SAE J2681 BRAKE TEST!

Replacement Parts By Kit

DBI-3.5K-MAXX
RTR/HUB-102-MAXX
CALP-3-6K-MAXX
DBB-3.5KI-MAXX
CALP-3-6K-BRAKE PAD

DBSO-6K-MAXX
RTR-120-MAXX
CALP-3-6K-MAXX
DBB-6K-MAXX
CALP-3-6K-BRAKE PAD

DBI-8KD9-MAXX (9/16)
RTR/HUB-131-8K-.56-MAXX
CALP-7-8K-MAXX
DBB-8KD-MAXX
CALP-7-8K-BRAKE PAD

DBI-8KA9-MAXX (9/16)
RTR/HUB-131-8K-.56-MAXX
CALP-7-8K-MAXX
DBB-8KA-MAXX
CALP-7-8K-BRAKE PAD

DBSO-3.5K-MAXX
RTR-109-MAXX
CALP-3-6K-MAXX
DBB-3.5K-MAXX
CALP-3-6K-BRAKE PAD

DBI-7K-MAXX
RTR/HUB-131-7K-MAXX
CALP-7-8K-MAXX
DBB-7K-MAXX
CALP-7-8K-BRAKE PAD

DBI-8KD10-MAXX (5/8)
RTR/HUB-131-8K-.62-MAXX
CALP-7-8K-MAXX
DBB-8KD-MAXX
CALP-7-8K-BRAKE PAD

****Optional Yellow Zinc Plated GOLD finish is available by replacing "MAXX" with "GOLD" on the kit part number and caliper part number****

DBI-6K-MAXX
RTR/HUB-120-MAXX
CALP-3-6K-MAXX
DBB-6K-MAXX
CALP-3-6K-BRAKE PAD

DBSO-7K-MAXX
RTR-131-7K-MAXX
CALP-7-8K-MAXX
DBB-7K-MAXX
CALP-7-8K-BRAKE PAD

DBSO-8KDD-MAXX
RTR-131-8K-MAXX
CALP-7-8K-MAXX
DBB-8KDD-MAXX
CALP-7-8K-BRAKE PAD

ELECTRIC-OVER-HYDRAULIC (EOH) BRAKE ACTUATORS with 360° position brake line connection



MODEL NO.	DESCRIPTION
TR-EOHA1600X	1600psi w/ Larger Fluid Capacity
TR-EOHA1600	1600psi for Disc Brakes
TR-EOHA1200	1200psi for Drum Brakes w/ 8k or Higher Axles
TR-EOHA1000	1000psi for Drum Brakes w/ 8k or Lower Axles

High Performance Brake Lines PASSED STORK SAEJ1401, FMVSS106

Quality Control: ALL brake hoses are 100% pressure tested at 3500psi

DOT Approved Rubber Flex Line

3/16" Brass Inverted Flare MALE on both ends

Low and High temperature ranges -50 °C to +121°C / -58° F to +250° F

RUBBER FLEX HOSE

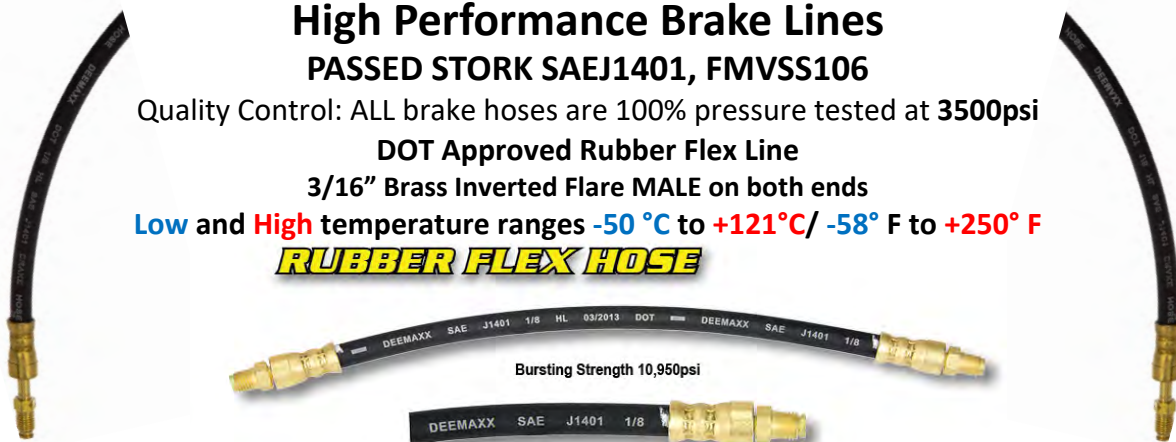

Bursting Strength 10,950psi

DOT-RFL-12"	DOT-RFL-24"	DOT-RFL-54"	DOT-RFL-78"	DOT-RFL-228"	DOT-RFL-260"
DOT-RFL-16"	DOT-RFL-36"	DOT-RFL-60"	DOT-RFL-96"	DOT-RFL-240"	DOT-RFL-280"
DOT-RFL-18"	DOT-RFL-38"	DOT-RFL-72"	DOT-RFL-220"	DOT-RFL-252"	DOT-RFL-312"

Custom sizes and stainless steel available.

Contact Us Today...

TRP International (Elkhart)
22420 Challenger Drive
Elkhart, IN. 46514
574.389.9941

trp[®]
www.trpintl.com

TRP International (Dallas)
324 S. Town East Blvd.
Mesquite, TX. 75149
972.279.9863