

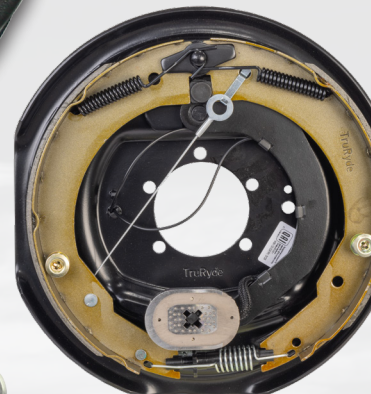

TruRyde®



PRODUCTS CATALOG

Axle, Suspension & Frame Components

SUPPLYING THE WORLD.



TRP International, LLC.

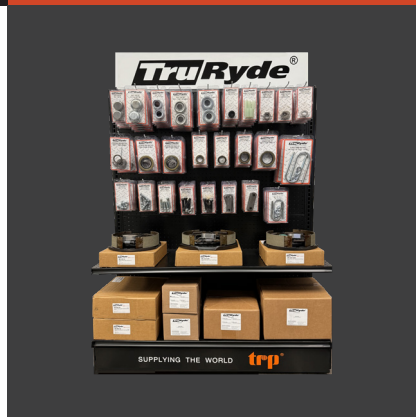

LETTER FROM THE PRESIDENT

Since 1992, TRP International has served the light and medium-duty trailer industry. The TruRyde brand of axle, suspension, and frame components is known for high value, consistent quality, and reliability.

TRP combines domestic state-of-the-art machining and assembly capabilities with extensive global sourcing to provide cost-effective solutions and on-time delivery. This version of our catalog represents a culmination of years of hard work in bringing together a complete line of components for RV, utility, and marine trailers with axle capacity ratings from 2,000 pounds up to 16,000 pounds.

The catalog features numerous new products, denoted by the NEW symbol. Please consult your TRP Account Executive for pricing, availability, and further information on these and all items in this catalog.

We are deeply grateful to our customers, vendors, and employees for their ongoing support, without which our success would not be possible. We value these relationships and remain committed to being loyal and dedicated partners well into the future.

We appreciate your interest in our axle, suspension, and frame components catalog and look forward to speaking with you about your product needs. The TRP International team is ready to serve you, our valued customer.

Sincerely,



Chris Mileger
President,
TRP International, LLC.

CONTENTS

02 / ABOUT TRP

10 / SPINDLES & ACCESSORIES

15 / TORSION AXLE COMPONENTS

16 / BEARINGS, CAPS & SEALS

22 / BRAKE DRUMS & IDLER HUBS

26 / BRAKES & BRAKE ACCESSORIES

34 / LEAF SPRINGS & BUSHINGS

38 / AXLE STAMPINGS & U-BOLTS

43 / RV SHOCK COMPONENTS

44 / SUSPENSION COMPONENTS

50 / SUSPENSION FASTENERS

52 / MOBILE HOME PRODUCTS

54 / MARINE PRODUCTS

64 / TOWING COMPONENTS

72 / PACKAGED PARTS

84 / AXLE & HUB COMPONENT DIAGRAMS

100 / CUSTOM MACHINING



THROUGHOUT THIS
CATALOG A TRP
SERVICE MARK
APPEARS NEXT TO
THOSE PRODUCTS
MANUFACTURED BY TRP

OUR STRATEGY

MISSION STATEMENT

Our mission is to provide our customers with an expansive line of quality products distributed on schedule, at competitive prices, with responsive and professional service.

VISION STATEMENT

The TRP group of companies will be a leading global supplier of axle, suspension, and other frame and trailer components to a variety of ground transportation equipment industries by providing excellent products and services to our customers, challenging opportunities for our employees, and positive contributions to our communities.

QUALITY POLICY

TRP International, LLC. is committed to using proven quality management principles to safely produce and source quality products and services that exceed customer expectations for value, performance, and reliability through continual improvement of our business systems.

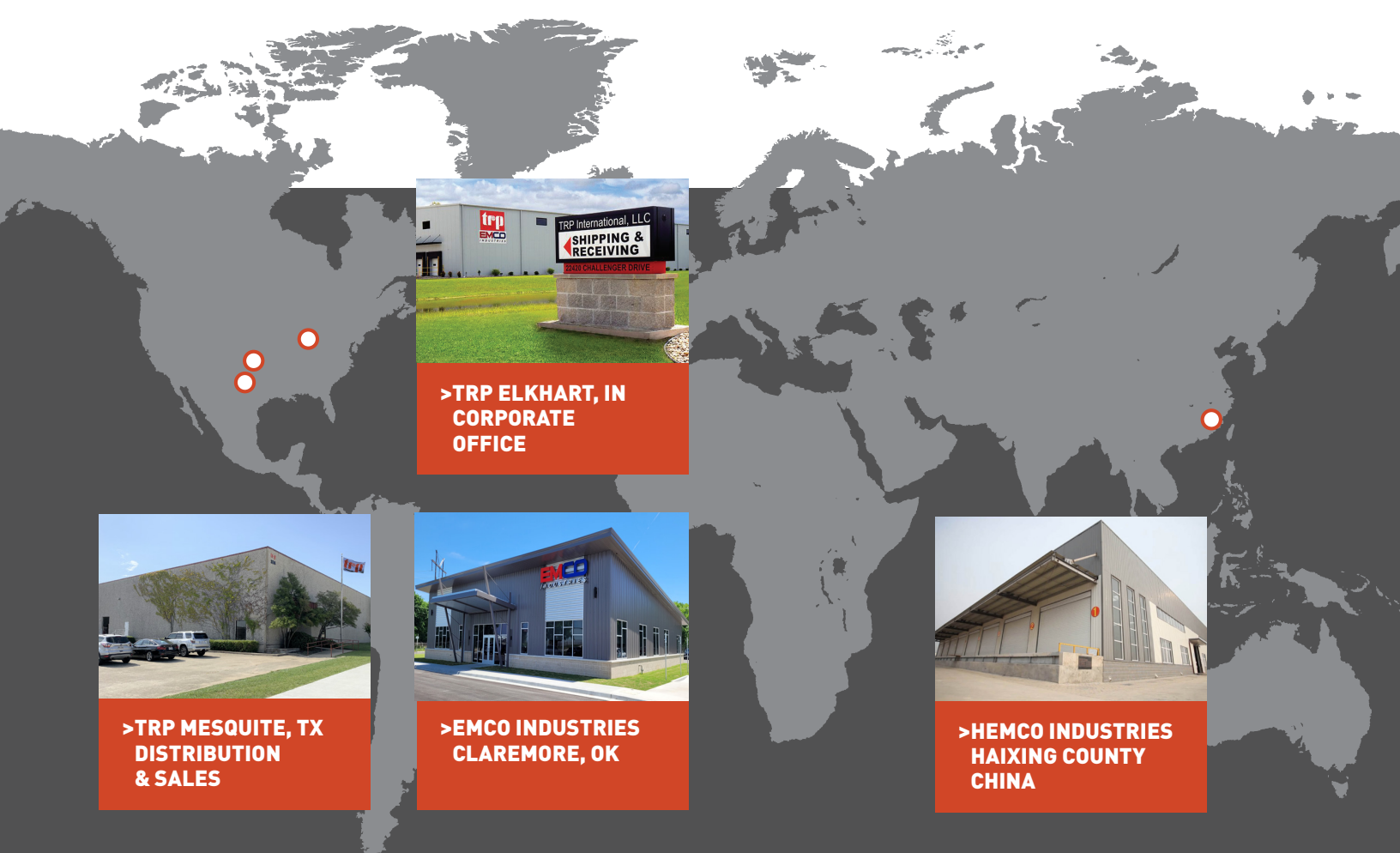

>TRP ELKHART, IN
CORPORATE
OFFICE



>TRP MESQUITE, TX
DISTRIBUTION
& SALES



>EMCO INDUSTRIES
CLAREMORE, OK



>HEMCO INDUSTRIES
HAIXING COUNTY
CHINA

OUR CORE VALUES



PEOPLE MATTER

People-oriented beliefs and values. Treating everyone with dignity, respect, understanding, and acting without prejudice. Offering mentorship, development, and empowerment.



CUSTOMER FOCUSED

Serving both internal team members and external customers' needs with a commitment to exceptional and timely support.



DOING RIGHT

Commitment to honesty, integrity, trust, and accountability. Decisions and actions benefiting our people, our customers, our vendors, and our communities.



RESULTS DRIVEN

Taking care of our people and partners in the areas of quality of life, service, and products. Focused on accurate, on-time delivery. Working with a proactive and positive attitude.



OUR EXPERTISE



ENGINEERING

Our engineering staff has experience in various design and manufacturing environments including leaf springs, tapered roller bearings, closed-die forgings, metal stampings, and CNC machining. Our resources include professional mechanical, quality, and metallurgical engineers. With these skills, we are striving every day to improve the overall cost and quality of the products we offer.



MANUFACTURING

The TRP companies take pride in the capabilities and efficiency of each piece of equipment used to manufacture our products. We strive to incorporate lean principles to keep costs down in our production facilities. Each facility takes pride in shipping quality products and maintains a quality system that builds the framework for verifying that we meet customer specifications.



INTERNATIONAL TRADE

With over three decades of international trade experience and qualified TRP personnel working through liaison offices in Italy and China, we have the expertise necessary to communicate, consult, coordinate and execute the many facets of importing products to North America from abroad.



DISTRIBUTION

With state-of-the-art technology for order processing and fulfillment combined with strategically located distribution centers, we can effectively serve the requirements of customers across the U.S., as well as Canada and Mexico. Our constant attention to logistics and evaluation of carrier performance and pricing, assures the most efficient, cost-effective shipping methods resulting in faster delivery and lower total product costs.

CUSTOM FORGING DIVISION

TRP International, LLC. established a business relationship with Ghioni & Valaperta, an Italian forging company, in 1992. Ghioni & Valaperta has specialized in custom closed-die steel forgings for over 50 years and provides forgings and finished components to companies like GKN, Stellantis, Audi, and Volkswagen. Through this relationship, TRP can access world-class forgings that combine unique technology and equipment with highly skilled employees.

Combining its sales, engineering, and distribution forces, TRP supplies forgings of unparalleled quality to its customers in North America. Always looking to increase its value-added capabilities, TRP acquired a production machine shop that now operates at TRP corporate headquarters in Elkhart, IN. The machine shop is equipped with highly capable, state-of-the-art machinery allowing TRP to consistently improve the quality of each component produced.

PRODUCTION MACHINING

TRP's in-house production machine shop in Elkhart, IN., is staffed with a team of highly experienced machinists who specialize in machining various axle and suspension components for the light and medium-duty trailer industry. We take immense pride in the capabilities and efficiency of each piece of equipment used to manufacture our products.

Our dedication to incorporating lean principles to keep costs down in our production facilities is matched only by our unwavering commitment to quality. Each TRP facility is committed to shipping only the highest quality products and maintains a robust quality system that ensures we consistently meet and exceed customer expectations.

TRP AGRICULTURAL DIVISION

Since 2011, TRP Agricultural Division has been a reliable supplier to the agricultural market, offering a wide range of components such as spindles, hubs, drums, brakes, bearings, seals, dust caps, and fasteners. We have recently expanded our product line to include jacks and couplers from the high-speed business.

Our commitment to customer satisfaction is evident in our extensive inventory of the most popular items and our ability to work with customer-designed products. By leveraging our domestic manufacturing capabilities, we provide a broad range of high-quality and competitively priced components.

EMCO INDUSTRIES

ABOUT EMCO INDUSTRIES

At EMCO Industries, we eat, live, and breathe spring steel. Manufacturing and distributing spring steel is our passion, which shows in our customer satisfaction.

With over thirty years in business, we have become well known for our complete line of leaf springs, agricultural components, and other heat-treated products. Our leaf springs can be found on heavy-duty trailers, RVs, boat trailers, open and closed utility trailers, specialty vehicles, agricultural equipment, and many other applications.

OUR HIGH-QUALITY PRODUCTS

EMCO Industries is a different kind of leaf spring manufacturer. We have the product knowledge and know-how to solve many spring-related problems, and we are the only domestic manufacturer with a company-owned facility in China. This allows us the flexibility to provide our customers with the best solution possible while maintaining control during

the entire process, from receiving your order until the product reaches your dock.

We have built our business on knowledge, continuous improvements, innovation, globalism, and professionalism. At the core of our company's approach lies lean manufacturing. This commitment drives us to continually seek opportunities to reduce expenses and enhance quality.

HEADQUARTERS AND FACILITIES

Our 95,000 square-foot manufacturing facility in Claremore, Oklahoma is centrally located in the U.S., minimizing freight charge and improving delivery times.

Our 200,000 square-foot Chinese manufacturing facility located in the Hebei Province, near Tianjin's port offers great access to ship products to the U.S., or wherever our customers require them. Our Chinese facility allows us to offer a blended supply solution to our customers.



In 2016, after merging with TRP International, LLC. with warehouse and distribution facilities in Elkhart, Indiana and Mesquite, Texas (Dallas county), together we are the ONLY spring supplier that can honestly say we have the solutions for your leaf spring needs.

UNWAVERING BACKBONE

From the earliest days of modern hauling trailers to their horse-drawn wagon forbearers, one component that has remained a constant is the highly functional and reliable leaf spring.

Trailers made for hauling come in three varieties: light-duty, medium-duty, and heavy-duty. Whatever size or type of load arc hauling, one thing they all have in common is that they need the right kind of suspension. Everything literally rides on the suspension. Leaf spring suspensions stand out as both reliable and cost-effective. They have been serving the hauling industry for years, with a proven track record.

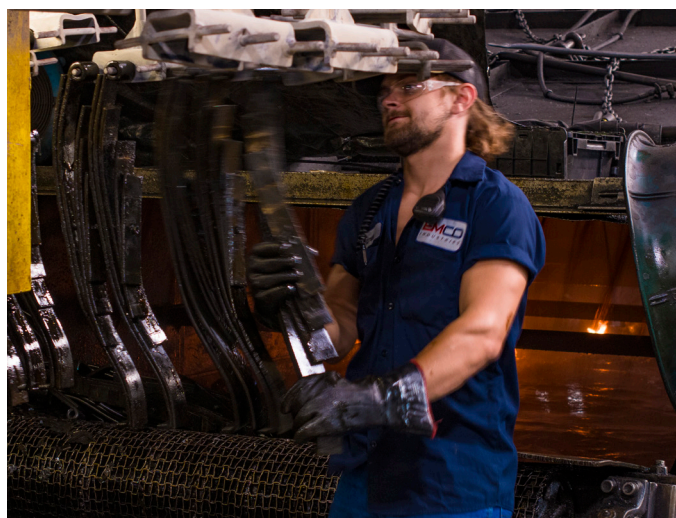

THE CRAFTSMANSHIP

Manufacturing leaf springs correctly is a meticulous operation. EMCO begins with automotive-grade, high carbon specialty steel. The material is then specifically processed to create EMCO's leaf springs.

EMCO has advanced heat-treating capabilities and the steel undergoes rigorous preparation for its final purpose. It's the quality of steel and the sophisticated heat-treating processes that is at the heart of our leaf spring quality.

EMCO'S highly-automated operations seamlessly produce hundreds of thousands of leaf springs every month, meeting the demands of our customer base. It's this quality and capacity that has made EMCO the undisputed leading supplier of springs to the light-and medium-duty trailer market which has driven the expansion into the heavy-duty, 22.5K axle leaf spring segment.

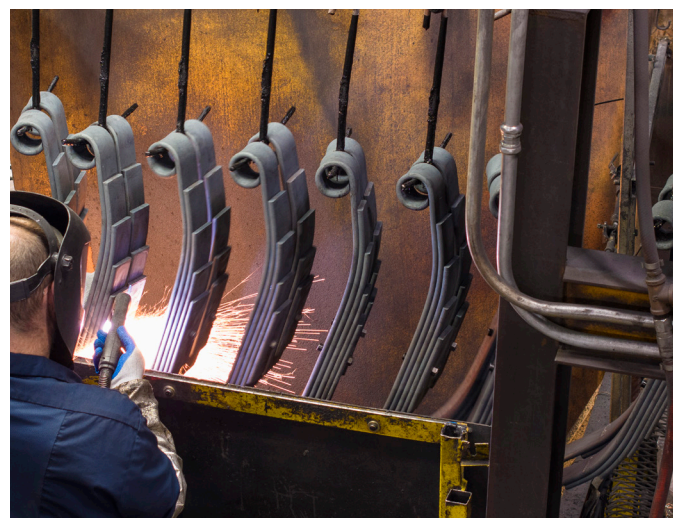



Butt Weld Style Spindles

**HOT FORGED
INTEGRATED FLANGE**

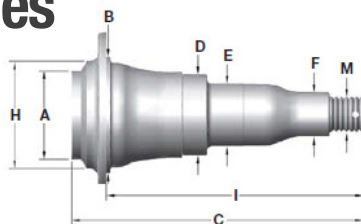

PART #	DESCRIPTION			DIMENSIONS							
	SPINDLE	AXLE CAPACITY	UNIT WT.	A	B	C	D	E	F	H	I
SP-HF-IF-84LZ	#84	3,500 lb.	3.29 lb.	1.95"	3.00"	6.35"	1.72"	1.376"	1.062"	2.45"	5.36"
SP-HF-IF-8455Z	#84	3,500 lb.	3.97 lb.	2.55"	3.00"	6.35"	1.72"	1.376"	1.062"	3.00"	5.46"
SP-HF-IFB-42LZ-213	#42	7,000 lb.	7.31 lb.	2.45"	3.25"	8.25"	2.13"	1.749"	1.249"	3.00"	7.25"
SP-HF-IFB-42LZ-225	#42	7,000 lb.	7.31 lb.	2.45"	3.25"	8.25"	2.25"	1.749"	1.249"	3.00"	7.25"
SP-HF-IF-8K	#42	8,000 lb.	12.00 lb.	2.93"	4.49"	10.49"	2.25"	1.749"	1.249"	3.50"	7.54"
SP-HF-IF-10K		10,000 lb.	27.27 lb.	3.19"	4.49"	14.96"	2.87"	2.249"	1.749"	4.00"	11.09"
SP-HF-IF-10KSHT-SEU319		10,000 lb.	25.00 lb.	3.19"	4.49"	13.00"	2.87"	2.249"	1.749"	4.00"	9.14"
SP-HF-IF-10KSHT-SEU409		10,000 lb.	27.23 lb.	4.09"	4.49"	13.00"	2.87"	2.249"	1.749"	5.00"	9.14"
SP-HF-IF-12K		12,000 lb.	38.18 lb.	4.09"	4.49"	15.67"	3.12"	2.624"	2.249"	5.00"	12.41"
SP-HF-IF-16K		16,000 lb.	42.00 lb.	3.86"	4.49"	17.54"	3.12"	2.624"	2.249"	5.00"	13.59"

HOT FORGED

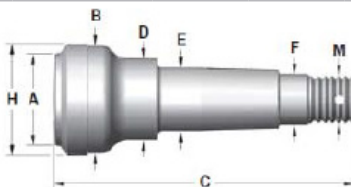

PART #	DESCRIPTION			DIMENSIONS							
	SPINDLE	AXLE CAPACITY	UNIT WT.	A	B	C	D	E	F	H	
SP-HF-84BT16	BT16	2,500 lb.	3.20 lb.	1.95"	2.26"	6.35"	1.50"	1.062"	1.062"	2.34"	
SP-HF-84L	#84	3,500 lb.	3.40 lb.	1.95"	2.26"	6.35"	1.72"	1.376"	1.062"	2.45"	
SP-HF-84S	#84	3,500 lb.	3.00 lb.	1.95"	2.26"	6.05"	1.72"	1.376"	1.062"	2.34"	
SP-HF-8455	#84	3,500 lb.	4.00 lb.	2.55"	2.26"	6.35"	1.72"	1.376"	1.062"	3.00"	
SP-HF-42L-213	#42	7,000 lb.	7.40 lb.	2.45"	2.74"	8.25"	2.13"	1.749"	1.249"	3.00"	
SP-HF-42L-225	#42	7,000 lb.	7.40 lb.	2.45"	2.74"	8.25"	2.25"	1.749"	1.249"	3.00"	
SP-HF-8K	#42	8,000 lb.	10.00 lb.	2.93"	2.74"	8.61"	2.25"	1.749"	1.249"	3.50"	

BAR STOCK

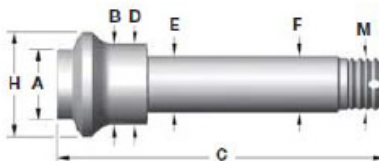

PART #	DESCRIPTION			DIMENSIONS							
	SPINDLE	AXLE CAPACITY	UNIT WT.	A	B	C	D	E	F	H	
SP-HF-BT8	BT8	2,000 lb.	2.00 lb.	1.31"	N/A	5.96"	1.25"	0.999"	0.999"	1.75"	
SP-HF-BT8L	BT8	2,000 lb.	2.25 lb.	1.31"	1.63"	6.68"	1.25"	0.999"	0.999"	1.75"	
SP-HF-BT16	BT16	2,500 lb.	2.25 lb.	1.31"	N/A	5.96"	1.50"	1.062"	1.062"	1.75"	
SP-HF-BT16L	BT16	2,500 lb.	2.50 lb.	1.31"	1.63"	6.68"	1.50"	1.062"	1.062"	1.75"	

Integrated Flange Drop Spindles

UTILITY

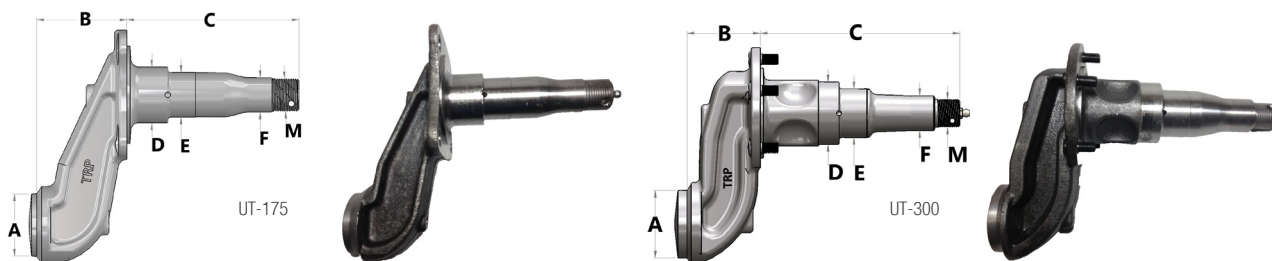

PART #	AXLE	DESCRIPTION	DIMENSIONS						UNIT WT.
			A	B	C	D	E	F	
SP-TT-IF-175Z	3,500 lb.	4" Drop For 2-3/8" Tube w/ Flange	1.95"	2.77"	5.36"	1.72"	1.376"	1.062"	6.63 lb.
SP-TT-IF-175AZ	3,500 lb.	4" Drop For 3" Tube w/ Flange	2.45"	2.77"	5.36"	1.72"	1.376"	1.062"	8.45 lb.
SP-UT-IFB-300Z-213	7,000 lb.	4" Drop For 3" Tube w/ Flange	2.45"	2.64"	7.25"	2.13"	1.749"	1.249"	12.25 lb.
SP-UT-IFB-300Z-225	7,000 lb.	4" Drop For 3" Tube w/ Flange	2.45"	2.64"	7.25"	2.25"	1.749"	1.249"	12.25 lb.
SP-UTH-400F	8,000 lb.	4" Drop w/ Forged Flange For 3-1/2" Tube	2.93"	3.00"	7.55"	2.25"	1.749"	1.249"	17.10 lb.

HOT FORGED DROP MARINE

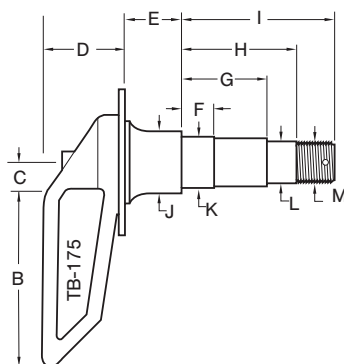

PART #	AXLE	DIMENSIONS												UNIT WT.
		A	B	C	D	E	F	G	H	I	J	K	L	
SP-TB-175F	3,500 lb.	2.03"	4.75"	1.00"	2.25"	1.26"	0.91"	2.38"	3.34"	4.12"	1.72"	1.376"	1.062"	7.75 lb.

ADDITIONAL SPECS

- Forging material: Custom engineered automotive quality high-strength steel
- 2-8K Spindles are machined to 1"- 14 UNS-2A thread (M) with .190" cotter pin hole, 10K to 1.5"-12, 12-16K to 1.75"-12
- Dimension "B" on hot forged Integrated flange straight spindles is the brake nib pilot dimension
- See pg 14 for Spindle Fasteners & Accessories
- See pg 12 for Custom Spindle options

Call for availability and lead time on spindles.

The specifications and dimensions above are for reference only.

AXLE PLACEMENT

The 2"x 2" or 2"x 3" tube is welded to the flat surface of the leg of the spindle.

AXLE DROPS

This spindle allows you to achieve a drop from 1.75" to 4.75".

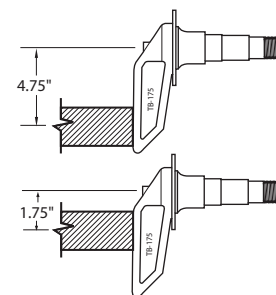

Bar Stock Spindles

ROUND

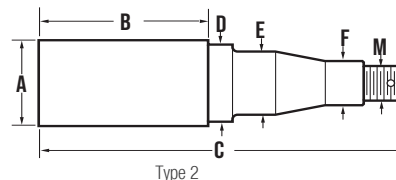
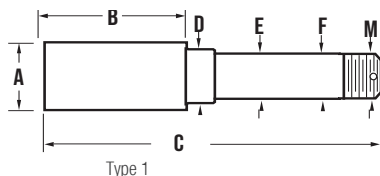

PART #	DESCRIPTION				DIMENSIONS					
	TYPE	SPINDLE	AXLE CAPACITY	UNIT WT.	A	B	C	D	E	F
SP-125BT8	1	BT8	2,000 lb.	2.25 lb.	1.25"	3.37"	8.25"	1.23"	0.999"	0.999"
SP-125BT16	1	BT16	2,500 lb.	2.25 lb.	1.25"	3.37"	8.25"	1.23"	1.062"	1.062"
SP-150BT8	1	BT8	2,000 lb.	2.75 lb.	1.50"	3.37"	8.25"	1.25"	0.999"	0.999"
SP-150BT16	1	BT16	2,500 lb.	3.00 lb.	1.50"	3.37"	8.25"	1.48"	1.062"	1.062"
SP-17584	2	#84	3,500 lb.	4.00 lb.	1.75"	3.37"	8.25"	1.72"	1.376"	1.062"
SP-20084	2	#84	3,500 lb.	5.00 lb.	2.00"	3.37"	8.25"	1.72"	1.376"	1.062"
SP-22542	2	#42	7,000 lb.	8.00 lb.	2.25"	6.00"	11.00"	2.23"	1.749"	1.249"

SQUARE

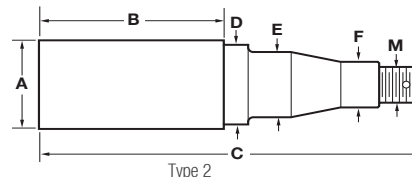
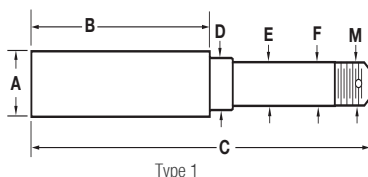
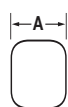

PART #	DESCRIPTION				DIMENSIONS					
	TYPE	SPINDLE	AXLE CAPACITY	UNIT WT.	A	B	C	D	E	F
SP-150BT8-SQ	1	BT8	2,000 lb.	2.60 lb.	1.50"	3.32"	8.25"	1.23"	0.999"	0.999"
SP-150BT16-SQ	1	BT16	2,500 lb.	2.90 lb.	1.50"	3.32"	8.25"	1.48"	1.062"	1.062"
SP-20484-SQ w/seal ring	2	#84	3,500 lb.	3.50 lb.	1.50"	3.53"	8.25"	1.72"	1.376"	1.062"
SP-35684-SQ	2	#84	3,500 lb.	4.00 lb.	1.75"	6.05"	11.00"	1.72"	1.376"	1.062"
SP-50642-SQ w/seal ring	2	#42	7,000 lb.	5.00 lb.	2.00"	5.93"	11.00"	2.25"	1.749"	1.249"

ADDITIONAL SPECS

- Bar stock material: SAE 1045 hot rolled
- All spindles are machined to 1" - 14" UNS-2A thread (M) with .190" cotter pin hole
- See pg 14 for Spindle Fasteners & Accessories

Call for availability and lead time on spindles.

CUSTOM SPINDLE OPTIONS (add to the end of part number)

- **F** = Welded brake flange;
- **FB** = Welded brake flange with studs.
NOTE: Studs are 3/8"-24 x 7/8". (Only for 5.2K - 7K axle)
- **Z** = Drilling for lubrication
- **ZD** = Drilling for lubrication with D-Flat
- **NW** = Add nut and washer
- **NWC** = Add nut, washer and cotter pin
- **SS** = Installation of stainless steel wear ring
- Custom machining available upon request

Brake Flanges



All Type 2 flanges are available with brake studs pressed in. Add "B" to end of flange part number.

Studs are 3/8"- 24 x 7/8".

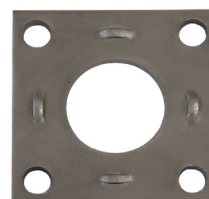
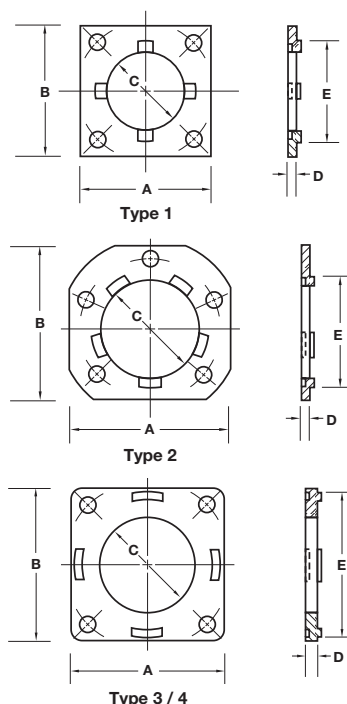

PFL-41 / Type 1



PFL-52 / Type 2

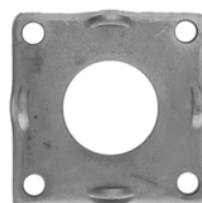

PFL-42.31 / Type 3

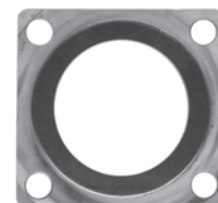

PFLD-42.96 2 / Type 4

PART #	TYPE	DIMENSIONS					BOLT CIRCLE	REF #	UNIT WT.	CASE QTY.	CASE WT.
		A	B	C	D	E					
PFL-41.30	1	3.75"	3.75"	1.30"	0.23"	3.00"	4.00"	—	0.75 lb.	2,000 pc.	1,500 lb.
PFL-41.51	1	3.75"	3.75"	1.51"	0.25"	3.00"	4.00"	4-29	0.82 lb.	1,500 pc.	1,230 lb.
PFL-41.64	1	3.75"	3.75"	1.64"	0.25"	3.00"	4.00"	4-34	0.77 lb.	1,500 pc.	1,155 lb.
PFL-41.75	1	3.75"	3.75"	1.75"	0.25"	3.00"	4.00"	4-16	0.73 lb.	4,000 pc.	2,920 lb.
PFL-42.27	1	3.75"	3.75"	2.27"	0.25"	3.00"	4.00"	4-12	0.62 lb.	4,000 pc.	2,480 lb.
PFL-52.31	2	4.44"	4.25"	2.31"	0.25"	3.25"	3.87"	4-6Q	0.80 lb.	4,000 pc.	3,200 lb.
PFL-52.75	2	4.44"	4.25"	2.75"	0.25"	3.25"	3.87"	4-6T	0.76 lb.	4,000 pc.	3,040 lb.
PFL-53.12	2	4.44"	4.25"	3.12"	0.25"	3.25"	3.87"	4-6	0.80 lb.	1,000 pc.	800 lb.
PFL-52.31-31	2	4.44"	4.25"	2.31"	0.31"	3.25"	3.87"	—	0.90 lb.	1,000 pc.	900 lb.
PFL-52.53	2	4.44"	4.25"	2.53"	0.25"	3.25"	3.87"	—	0.90 lb.	1,000 pc.	900 lb.
PFL-52.53-31	2	4.44"	4.25"	2.53"	0.31"	3.25"	3.87"	—	0.90 lb.	1,000 pc.	900 lb.
PFL-42.31	3	4.75"	4.75"	2.31"	0.37"	4.50"	5.28"	—	1.90 lb.	550 pc.	1,050 lb.
PFL-42.56	3	4.75"	4.75"	2.56"	0.37"	4.50"	5.28"	—	1.90 lb.	550 pc.	1,050 lb.
PFL-42.96	3	4.75"	4.75"	2.96"	0.37"	4.50"	5.28"	—	1.90 lb.	550 pc.	1,050 lb.
PFL-43.12	3	4.75"	4.75"	3.12"	0.37"	4.50"	5.28"	—	1.90 lb.	550 pc.	1,050 lb.
PFL-43.53	3	4.75"	4.75"	3.53"	0.37"	4.50"	5.28"	—	1.90 lb.	550 pc.	1,050 lb.
PFLD-42.96	4	4.63"	4.63"	2.96"	0.26"	3.87"	4.96"	—	1.90 lb.	550 pc.	1,050 lb.

ADDITIONAL SPECS

- Material: High quality pickled and oiled structural steel per ASTM specifications
- Bolt hole size: Type 1 - .48", Type 2 - .41", Type 3 / 4 - .53"
- Type 4 flange has 360° machined locating nibs

Spindle Fasteners & Accessories

TANG WASHER

PART #	DIMENSIONS			BOX QTY.	BOX WT.
	A	B	C		
FA-TW100	1.57"	1.00"	0.40"	1,100 pc.	35 lb.

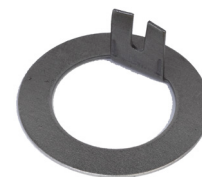
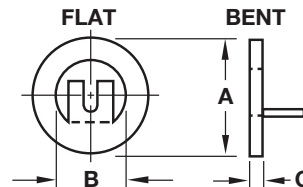

FLAT ROUND SPINDLE WASHER

PART #	DIMENSIONS			BOX QTY.	BOX WT.
	A	B	C		
FA-SW100	1.67"	1.00"	0.13"	660 pc.	50 lb.

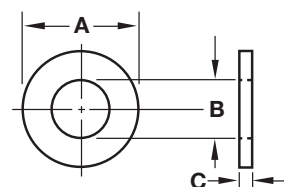

FLAT D-WASHER

PART #	DIMENSIONS				BOX QTY.	BOX WT.
	A	B	C	D		
FA-DW100	1.67"	1.00"	0.88"	0.13"	700 pc.	45 lb.

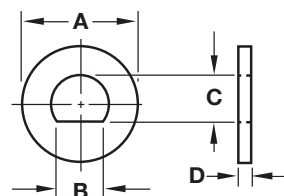

SPINDLE NUT

PART #	THREAD	DIMENSIONS			BOX QTY.	BOX WT.
		A	B	C		
FA-SN100	1"-14 N.F.	1.46"	1.00"	0.55"	180 pc.	42 lb.

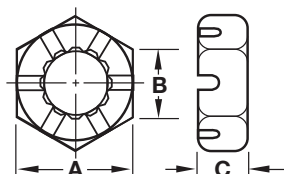

COTTER PIN

PART #	SIZE	DIMENSIONS	BOX QTY.	BOX WT.
		A		
FA-CP175	1/8" x 1-3/4"	1.75"	1,400 pc.	12 lb.

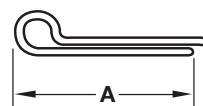

STAINLESS STEEL WEAR RINGS

PART #	DIMENSIONS			BOX QTY.	BOX WT.	
	SPINDLE	A	B			C
WR-SS125	BT	1.22"	1.07"	0.61"	1,000 pc.	10 lb.
WR-SS138	BT	1.38"	1.16"	0.27"	1,000 pc.	10 lb.
WR-SS150	BT	1.50"	1.20"	0.65"	1,000 pc.	10 lb.
WR-SS175	#84	1.72"	1.39"	0.62"	1,000 pc.	12 lb.
WR-SS213	#42	2.13"	1.85"	0.59"	500 pc.	6 lb.
WR-SS225	#42	2.24"	1.87"	0.75"	500 pc.	7 lb.

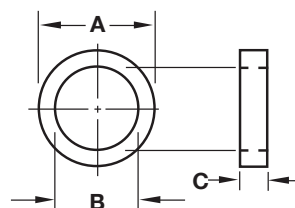

GREASE ZERK

PART #	SIZE	DIMENSIONS			BOX QTY.	BOX WT.
		A	B	C		
FA-ZERK	1/4" - 28 Taper	0.56"	0.26"	0.21"	5,000 pc.	32 lb.

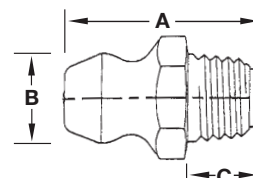

Torsion Axle Components



2,000 LB. - 10,000 LB.

Easy installation with less overall maintenance. Torsion axles are ideal for minimizing road shock. For use on cargo, marine, agricultural and multi-use trailers. The rubber cord absorbs travel noise, creating a quiet, smoother ride than sprung axles and serves as extra protection for your cargo. Use with electric, hydraulic or disc brakes.

We offer solid steel inner bars, forged torsion arms with various starting angles for correct trailer height, precision machined steel spindles, and rubber cords for 2K to 10K axles.

PART #	DESCRIPTION
IB-20	2K Inner Bar Machined
IB-35	3.5K Inner Bar Machined
IB-60	6K Inner Bar Machined
IB-70	7K Inner Bar Machined
IB-80	8K Inner Bar Machined
IB-100	10K Inner Bar Machined
RC-20	2K #9 Torsion Rubber Cord, 0.700" D x 31.00" L
RC-35	3.5K #10 Torsion Rubber Cord, 0.825" D x 31.00" L
RC-60	6K #11 Torsion Rubber Cord, 0.975" D x 31.00" L
RC-70	7K #12 Torsion Rubber Cord, 1.125" D x 30.00" L
RC-80	8K-10K #13 Torsion Rubber Cord, 1.250" D x 31.00" L
SP-T20	2K Torsion Spindle,
SP-T35	3.5K Torsion Spindle
SP-T60	6K-7K Torsion Spindle
SP-T80	8K Torsion Spindle
SP-T100	10K Torsion Spindle
TA-20	2K Torsion Arm
TA-35	3.5K Torsion Arm
TA-60	6K Torsion Arm
TA-70	7K Torsion Arm
TA-80	8K Torsion Arm
TA-100	10K Torsion Arm

*See Page 12 for Custom Spindle Options

*Contact us for complete pressed and welded Z Bar assembly pricing.

The specifications and dimensions above are for reference only.



TORSION SPINDLE



TORSION ARM



TORSION INNER BAR



TORSION RUBBER CORD

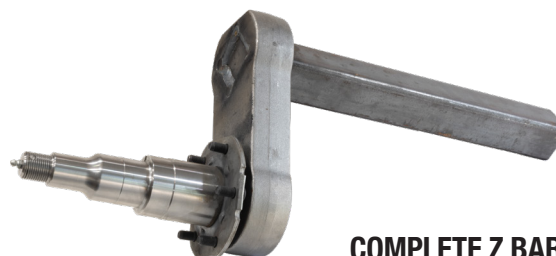

COMPLETE Z BAR

Tapered Roller Bearings



PART #	DESC.	CONE ID	CUP OD	BOX QUANTITY	BOX WEIGHT	CASE QUANTITY	CASE WEIGHT
L-44649	Cone	1.0625"	—	297 pc.	52 lb.	10,692 pc.	1,872 lb.
L-44643	Cone	1.0000"	—	297 pc.	59 lb.	10,692 pc.	2,124 lb.
L-44610	Cup	—	1.9800"	297 pc.	27 lb.	10,692 pc.	972 lb.
L-68149	Cone	1.3775"	-	184 pc.	47 lb.	6,624 pc.	1,692 lb.
L-68111	Cup	—	2.3612"	184 pc.	27 lb.	6,624 pc.	972 lb.
L-68110	Cup	—	2.3280"	184 pc.	25 lb.	6,624 pc.	900 lb.
LM-67048	Cone	1.2500"	—	184 pc.	49 lb.	6,624 pc.	1,764 lb.
LM-67010	Cup	—	2.3280"	184 pc.	25 lb.	6,624 pc.	900 lb.
25580	Cone	1.7500"	—	55 pc.	52 lb.	1,980 pc.	1,872 lb.
25590	Cone	1.7960"	—	55 pc.	52 lb.	1,980 pc.	1,872 lb.
25520	Cup	—	3.2650"	55 pc.	26 lb.	1,980 pc.	936 lb.
LM-11749	Cone	0.6875"	-	400 pc.	50 lb.	14,400 pc.	1,800 lb.
LM-11710	Cup	—	1.5700"	450 pc.	42 lb.	16,200 pc.	1,512 lb.
LM-11949	Cone	0.7500"	—	360 pc.	65 lb.	12,960 pc.	2,340 lb.
LM-11910	Cup	—	1.7810"	360 pc.	36 lb.	12,960 pc.	1,296 lb.
LM-12749	Cone	0.8661"	—	350 pc.	54 lb.	12,600 pc.	1,944 lb.
LM-12710	Cup	—	1.7810"	380 pc.	33 lb.	13,680 pc.	1,188 lb.
LM-12711	Cup	—	1.8110"	380 pc.	36 lb.	13,680 pc.	1,296 lb.
LM-48548	Cone	1.3750"	—	140 pc.	53 lb.	5,040 pc.	1,908 lb.
LM-48510	Cup	—	2.5625"	140 pc.	38 lb.	5,040 pc.	1,368 lb.
LM-501349	Cone	1.6250"	—	105 pc.	51 lb.	3,780 pc.	1,836 lb.
LM-603011	Cup	—	3.0625"	80 pc.	22 lb.	2,880 pc.	792 lb.
LM-603049	Cone	1.7812"	—	80 pc.	43 lb.	2,880 pc.	1,548 lb.
LM-501310	Cup	—	2.8910"	105 pc.	39 lb.	3,780 pc.	1,404 lb.
JLM-506810	Cup	—	3.5433"	54 pc.	22 lb.	1,944 pc.	792 lb.
JLM-506849	Cone	2.1653"	—	54 pc.	43 lb.	1,944 pc.	1,548 lb.
JL-69349	Cone	1.4961"	—	152 pc.	53 lb.	5,472 pc.	1,908 lb.
JL-69310	Cup	—	2.4803"	152 pc.	32 lb.	5,472 pc.	1,152 lb.
14125A	Cone	1.2500"	—	108 pc.	40 lb.	3,888 pc.	1,440 lb.
14276	Cup	—	2.7170"	108 pc.	19 lb.	3,888 pc.	684 lb.
HM-218248	Cone	3.5423"	—	12 pc.	40 lb.	432 pc.	1,440 lb.
HM-218210	Cup	—	5.7864"	16 pc.	20 lb.	576 pc.	720 lb.
HM-212049	Cone	2.6250"	—	24 pc.	45 lb.	864 pc.	1,620 lb.
HM-212011	Cup	—	4.8125"	20 pc.	34 lb.	720 pc.	1,224 lb.
HM-518410	Cup	—	6.000"	16 pc.	27 lb.	576 pc.	972 lb.
HM-518445	Cone	3.500"	—	10 pc.	46 lb.	360 pc.	1,656 lb.
LM-29710	Cup	—	2.5625"	140 pc.	24 lb.	5,040 pc.	864 lb.
LM-29749	Cone	1.5000"	—	140 pc.	46 lb.	5,040 pc.	1,656 lb.

Tapered Roller Bearings



PART #	DESC.	CONE ID	CUP OD	BOX QUANTITY	BOX WEIGHT	CASE QUANTITY	CASE WEIGHT
15123	Cone	1.2500"	—	120 pc.	41 lb.	4,320 pc.	1,476 lb.
15245	Cup	—	2.4409"	120 pc.	23 lb.	4,320 pc.	828 lb.
25821	Cup		2.8750"	84 pc.	33 lb.	3,024 pc.	1,188 lb.
25877	Cone	1.4750"		84 pc.	50 lb.	3,024 pc.	1,188 lb.
2720	Cup		3.0000"	84 pc.	33 lb.	3,024 pc.	1,188 lb.
2790	Cone	1.3125"		84 pc.	54 lb.	3,024 pc.	1,944 lb.
28580	Cone	2.000"	—	54 pc.	54 lb.	1,944 pc.	1,944 lb.
28521	Cup	—	3.6250"	54 pc.	29 lb.	1,944 pc.	1,044 lb.
28622	Cup		3.6250"	40 pc.	31 lb.	1,440 pc.	1,116 lb.
28682	Cone	2.250"	—	40 pc.	43 lb.	1,440 pc.	1,548 lb.
33275	Cone	2.750"		24 pc.	40 lb.	864 pc.	1,440 lb.
33462	Cup		4.6250"	24 pc.	30 lb.	864 pc.	1,080 lb.
342	Cup		3.1250"	60 pc.	30 lb.	2,160 pc.	1,080 lb.
3490	Cone	1.500"		60 pc.	40 lb.	2,160 pc.	1,440 lb.
3720	Cup		3.6718"	45 pc.	28 lb.	1,620 pc.	1,008 lb.
3780	Cone	2.000"		45 pc.	54 lb.	1,620 pc.	1,944 lb.
382A	Cup		3.8125"	54 pc.	21 lb.	1,944 pc.	756 lb.
387A	Cone	2.250"		48 pc.	45 lb.	1,728 pc.	1,620 lb.
387AS	Cone	2.250"		54 pc.	50 lb.	1,944 pc.	1,800 lb.
3920	Cup		4.4375"	24 pc.	24 lb.	864 pc.	864 lb.
394A	Cup		4.3307"	40 pc.	28 lb.	1,440 pc.	1,008 lb.
395S	Cone	2.625"		24 pc.	33 lb.	864 pc.	1,188 lb.
39520	Cup		4.4375"	24 pc.	25 lb.	864 pc.	900 lb.
39585	Cone	2.500"		24 pc.	40 lb.	864 pc.	1,440 lb.
3984	Cone	2.620"		24 pc.	37 lb.	864 pc.	1,332 lb.
453A	Cup		4.2500"	24 pc.	24 lb.	864 pc.	864 lb.
460	Cone	1.7500"		24 pc.	40 lb.	864 pc.	1,440 lb.
572	Cup		5.1150"	16 pc.	30 lb.	576 pc.	1,080 lb.
580	Cone	3.250"		12 pc.	35 lb.	432 pc.	1,260 lb.
02475	Cone	1.250"	—	80 pc.	40 lb.	2,880 pc.	1,440 lb.
02420	Cup	—	2.6875"	80 pc.	27 lb.	2,880 pc.	972 lb.
JM205149	Cone	1.9685"	—	45 pc.	44 lb.	1,620 pc.	1,584 lb.
JM205110	Cup	—	3.5433"	50 pc.	26 lb.	1,800 pc.	936 lb.
JM511946	Cone	2.5591"	—	36 pc.	52 lb.	1,296 pc.	1,872 lb.
JM511910	Cup	—	4.3307"	36 pc.	32 lb.	1,296 pc.	1,152 lb.
JM207010	Cup		3.7402"	36 pc.	52 lb.	1,296 pc.	1,872 lb.
JM207049	Cone	2.1654"		36 pc.	32 lb.	1,296 pc.	1,152 lb.

- For non-stock items minimum order quantities and longer lead time will apply.
- See Packaged Parts on pg 73

The specifications and dimensions above are for reference only.

Seals



GS-2250DL

DOUBLE LIP GREASE SEALS

PART #	PACKAGED PARTS KIT#	AXLE CAPACITY	SHAFT DIAM.	BORE DIAM.	SEAL OD.	SEAL WIDTH	SPINDLE	REF. #	BOX QTY.	BOX WT.
GS-1250DL	PP-GSK-1	2,000 lb.	1.250"	1.983"	1.983"	0.250"	BT8	12192TB	1,680 pc.	50 lb.
GS-1500DL	PP-GSK-2	2,500 lb.	1.500"	1.983"	1.983"	0.250"	BT16	15192TB 139514	1,680 pc.	54 lb.
GS-1687DL	N/A	3,500 lb.	1.687"	2.561"	2.565"	0.500"	#84	168255TB	1,200 pc.	40 lb.
GS-1719DL	PP-GSK-3	3,500 lb.	1.719"	2.561"	2.565"	0.500"	#84	171255TB 122087	480 pc.	39 lb.
GS-2125DL	PP-GSK-4	7,000 lb.	2.125"	3.371"	3.376"	0.313"	#42	21333TB	300 pc.	29 lb.
GS-2250DL	PP-GSK-5	8,000 lb.	2.250"	3.371"	3.376"	0.375"	#42	22333TB 122088	300 pc.	31 lb.

- See Packaged Parts on pg 73
- For non-stock items minimum order quantities and longer lead time will apply.



GS-2250DLR

DOUBLE LIP RUBBER COATED GREASE SEALS

PART #	AXLE CAPACITY	SHAFT DIAM.	BORE DIAM.	SEAL OD.	SEAL WIDTH	SPINDLE	REF. #	BOX QTY.	BOX WT.
GS-1250DLR	2,000 lb.	1.250"	1.983"	1.986"	0.406"	BT8	12194TC	1,120 pc.	49 lb.
GS-1500DLR	2,500 lb.	1.500"	1.983"	1.990"	0.250"	BT16	15192TC	1,680 pc.	54 lb.
GS-1687DLR	3,500 lb.	1.687"	2.561"	2.568"	0.500"	#84	168255TC	1,200 pc.	40 lb.
GS-1719DLR	3,500 lb.	1.719"	2.561"	2.568"	0.500"	#84	171255TC	480 pc.	39 lb.
GS-2125DLR	7,000 lb.	2.125"	3.371"	3.378"	0.375"	#42	21333TC	300 pc.	33 lb.
GS-2250DLR	8,000 lb.	2.230"	3.371"	3.378"	0.375"	#42	22333TC	300 pc.	35 lb.

- For non-stock items minimum order quantities and longer lead time will apply.

Seals



GS-2250TLR

TRIPLE LIP RUBBER COATED GREASE SEALS

PART #	AXLE CAPACITY	SHAFT DIAM.	BORE DIAM.	SEAL OD.	SEAL WIDTH	SPINDLE	REF. #	BOX QTY.	BOX WT.
GS-1250TLR	2,000 lb.	1.250"	1.983"	1.983"	0.250"	BT8	N/A	1,680 pc.	50 lb.
GS-1500TLR	2,500 lb.	1.500"	1.983"	1.983"	0.250"	BT16	N/A	1,680 pc.	50 lb.
GS-1687TLR	3,500 lb.	1.687"	2.561"	2.565"	0.500"	#84	N/A	1,200 pc.	50 lb.
GS-1719TLR	3,500 lb.	1.719"	2.561"	2.565"	0.500"	#84	N/A	480 pc.	50 lb.
GS-2250TLR	8,000 lb.	2.250"	3.371"	3.376"	0.375"	#42	N/A	300 pc.	31 lb.

ADDITIONAL SPECS

- Material: Rubber= Nitrile Buna - 70 durometer compound
- All Double Lip and Triple Lip seals are spring loaded
- For non-stock items minimum order quantities and longer lead time will apply.



OS-2250UNI

UNITIZED OIL SEALS

PART #	PACKAGED PARTS KIT#	AXLE CAPACITY	SHAFT DIAM.	BORE DIAM.	SEAL OD.	SEAL WIDTH	REF. #	BOX QTY.	BOX WT.
OS-2250UNI	PP-OSK-1	8,000 lb.	2.250"	3.372"	0.490"	0.500"	10-63 276712	140 pc.	41 lb.
OS-2875UNI	PP-OSK-2	10,000 lb.	2.875"	3.875"	0.515"	0.500"	10-51 176692	110 pc.	45 lb.
OS-3125UNI	PP-OSK-3	16,000 lb.	3.125"	4.500"	0.600"	0.500"	10-56 295924	80 pc.	56 lb.

- See Packaged Parts on pg 73



GS-1938NYL

NYLON MOBILE HOME GREASE SEAL

PART #	AXLE CAPACITY	SHAFT DIAM.	BORE DIAM.	SEAL OD.	SEAL WIDTH	REF. #	BOX QTY.	BOX WT.
GS-1938NYL	6,000 lb.	1.938"	2.534"	2.507"	0.375"	10-41	500 pc.	10 lb.

Dust Caps



Dust Cap

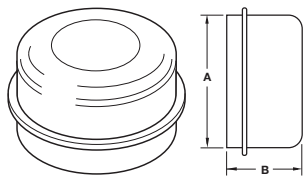

Lubed Dust Cap

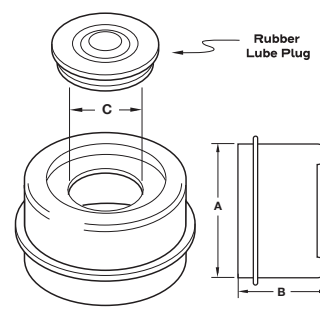

PART #	PACKAGED PARTS KIT#	DESCRIPTION	DIMENSIONS			REF #	BOX QTY.	BOX WT.
			A	B	C			
DC-178	N/A	1-3/4" Dust Cap, 2K	1.78"	1.30"	N/A	N/A	750 pc.	44 lb.
DC-200	PP-DC-1	2" Dust Cap, 2.2K-4.4K	1.99"	1.20"	N/A	21-3	550 pc.	42 lb.
DC-200L	PP-DC-4	2" Lubed Dust Cap, 2.2K - 4.4K	1.99"	1.40"	1.18"	21-41	440 pc.	40 lb.
DC-233	N/A	2-1/3" Dust Cap, 5K	2.33"	1.00"	N/A	N/A	500 pc.	49 lb.
DC-250	PP-DC-2	2-1/2" Dust Cap, 5.2K - 6K	2.45"	1.34"	N/A	21-1	360 pc.	44 lb.
DC-250L	PP-DC-5	2-1/2" Lubed Dust Cap, 5.2K - 6K	2.45"	1.52"	1.18"	21-42	290 pc.	38 lb.
DC-275	PP-DC-3	2-3/4" Dust Cap, 7K - 8K	2.72"	1.28"	N/A	21-39	430 pc.	69 lb.
DC-275L	PP-DC-6	2-3/4" Lubed Dust Cap, 7K-8K	2.72"	1.52"	1.18"	21-43	430 pc.	37 lb.
DC-RP	PP-DC-7	Universal Rubber Lube Plug fits 1.18" Lubed Dust Cap Hole, 2.2K-8K			1.18"	N/A	3,000 pc.	43 lb.

ADDITIONAL SPECS

- Material: 22 gauge, zinc coated steel except for PN: DC-275, which is 16 gauge
- Bright chrome plate available. Minimum order quantities and longer lead time will apply
- Stainless steel construction available. Minimum order quantities and longer lead time will apply
- See Packaged Parts on pg 73

Oil Caps

TRURYDE DEFENDER

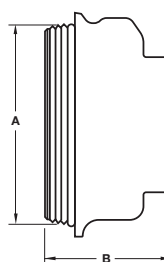

Defender Oil Cap

PART #	PACKAGED PARTS KIT#	DESCRIPTION	DIMENSIONS			REF #	BOX QTY.	BOX WT.
			A	B	C			
DC-O-288	PP-DC-11	Dust Cap, Oil, 8K, 2.88"	2-7/8" - 12 UN2A	1.85"	1.50"	LCI85373928	100 pc.	48 lb.
DC-G-288	PP-DC-12	Dust Cap, Grease, 8K, 2.88"	2-7/8" - 12 UN2B	1.85"	1.50"	LCI 85373929	100 pc.	48 lb.
DC-O-375	N/A	Dust Cap, Oil, 9K-16K, 3.75"	3-3/4" - 8 UN2B	2.33"	2.00"	K71-859-00	48 pc.	36 lb.
DC-G-375	N/A	Dust Cap, Grease, 9K-16K, 3.75"	3-3/4" - 8 UN2B	2.33"	2.00"	K71-859-00	48 pc.	36 lb.
DC-O-400	PP-DC-13	Dust Cap, Oil, 10K-16K, 4"	4" - 12 UN2A	2.33"	2.00"	LCI85373928	48 pc.	36 lb.
DC-G-400	PP-DC-14	Dust Cap, Grease, 10K-16K, 4"	4" - 12 UN2A	2.33"	2.00"	LCI85373928	48 pc.	36 lb.

ADDITIONAL SPECS

- Material: Die cast aluminum, silver powder coated
- Oil version: Clear lexan lens. Grease version: Black lexan lens
- Magnetized drain and fill plug
- See Packaged Parts on pg 73

FROM THE **FOUNDER**

At TRP International, we understand that partnerships are like puzzles—each piece is vital in completing the bigger picture. Since 1992, we've been helping businesses like yours find the right pieces to build success, offering practical solutions designed to help you grow and thrive.

With three strategically placed warehouse locations across the country and an extensive inventory of trailer parts, we ensure fast, reliable service to meet your needs. From small components to large orders, we're committed to keeping your business moving.

We're also proud to partner with our sister company, EMCO Industries, the leading domestic leaf spring manufacturer. EMCO specializes in high-quality, AMERICAN-MADE leaf springs and provides dependable trailer and suspension systems solutions.

Additionally, our state-of-the-art machining facility and engineering department in Elkhart, Indiana, allow us to offer custom manufacturing and design services. Whether you need a unique part or modifications to an existing product, our team is ready to collaborate with you.

At TRP, we believe every connection matters—whether with our long-time customers or those new to the industry. As the trailer parts landscape evolves, we're here to ensure you have all the pieces you need to complete your puzzle and succeed.

At TRP International, we take pride in leveraging our extensive network of global supply chain partnerships to bring unparalleled value and reliability to our clients. By sourcing directly from our trusted partners, we provide top-quality products, cutting-edge solutions, and seamless logistics. Our commitment to building strong, collaborative relationships enables us to deliver tailored services that meet your unique needs, helping your business thrive in a competitive market. With TRP International, you gain more than a supplier—you gain a trusted partner dedicated to your success.

Sincerely,

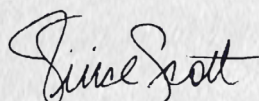

Vince Scott
Founder,
TRP International, LLC.

Brake Drums

LIGHT DUTY



PART #	PACKAGED PARTS KIT #	DESCRIPTION				UNIT WEIGHT	CASE QUANTITY	CASE WEIGHT
		AXLE CAP.	BOLT DIAM.	INNER RACE	OUTER RACE			
RVD-BT-5450	PP-RVDK-1 PP-RVDK-1PG	2,500 lb.	5 on 4.50"	L-44649	L-44649	18.90 lb.	125 pc.	2,415 lb.
RVD-U-5450	PP-RVDK-2 PP-RVDK-2PG	3,500 lb.	5 on 4.50"	L-68111	L-44610	21.10 lb.	72 pc.	1,600 lb.
RVD-U-5475	PP-RVDK-3 PP-RVDK-3PG	3,500 lb.	5 on 4.75"	L-68111	L-44610	21.10 lb.	72 pc.	1,600 lb.
RVD-U-5500	PP-RVDK-4 PP-RVDK-4PG	3,500 lb.	5 on 5.00"	L-68111	L-44610	21.10 lb.	72 pc.	1,600 lb.
RVD-U-5550	PP-RVDK-5 PP-RVDK-5PG	3,500 lb.	5 on 5.50"	L-68111	L-44610	21.10 lb.	72 pc.	1,600 lb.
RVD-U-6550	PP-RVDK-6 PP-RVDK-6PG	3,500 lb.	6 on 5.50"	L-68111	L-44610	22.00 lb.	72 pc.	1,650 lb.
RVD-H-655	PP-RVDK-7 PP-RVDK-7PG	6,000 lb.	6 on 5.50"	25520	15245	31.70 lb.	45 pc.	1,480 lb.
RVD-H-865	PP-RVDK-8 PP-RVDK-8PG	7,000 lb.	8 on 6.50"	25520	14276	37.00 lb.	45 pc.	1,715 lb.
RVD-H-865-916	PP-RVDK-9 PP-RVDK-9PG	7,000 lb.	8 on 6.50"	25520	14276	37.00 lb.	45 pc.	1,715 lb.
MHD-122459-RCB	N/A MOBILE HOME	6,000 lb.	5 on 9.4"	L-68111	LM-67010	25.00 lb.	90 pc.	2,290 lb.
RVD-UTG-510.13	N/A MOBILE HOME	7,000 lb.	5 on 9.4"	25520	15245	37.00 lb.	45 pc.	1,705 lb.

ADDITIONAL SPECS

- Studs are 1/2" - 20 with zinc plating (RVD-H-865-916 studs are 9/16" - 18)
- Mobile Home Drum includes Rim Clamps & 9/16" -18 Bolts
- Manufactured to automotive standard in ISO/TS-16949 registered factory
- ASTM test bar method used to monitor tensile strength
- Drums are chemically cleaned and painted black in electrostatic booth
- Packaged Part Drum Kit and Pre-Greased Drum Kit contents listed on Page 74
- See Packaged Parts on pg 76

**OPTIONAL PRE-GREASED
DRUMS & HUBS**

Brake Drums

MEDIUM DUTY



BD-10K-865



BD-12K/16K



8K, 8 on 6.5"



12K, 8 on 6.5"

PART #	DESCRIPTION				UNIT WEIGHT	CASE QTY.	CASE WEIGHT
	AXLE CAP.	BOLT DIA.	INNER RACE	OUTER RACE			
RVD-8KHYB-865-916	8,000 lb.	8 on 6.50"	25520	02420	36.37 lb.	45 pc.	1,687 lb.
RVD-8KHYB-865-580	8,000 lb.	8 on 6.50"	25520	02420	36.40 lb.	45 pc.	1,690 lb.
RVD-8K-865-916-G	8,000 lb.	8 on 6.50"	25520	02420	51.40 lb.	36 pc.	1,900 lb.
RVD-8K-865-580-G	8,000 lb.	8 on 6.50"	25520	02420	51.90 lb.	36 pc.	1,918 lb.
RVD-8K-865-916	8,000 lb.	8 on 6.50"	25520	02420	51.40 lb.	36 pc.	1,900 lb.
RVD-8K-865-580	8,000 lb.	8 on 6.50"	25520	02420	51.90 lb.	36 pc.	1,918 lb.
RVD-8K-865DUAL-580	8,000 lb.	8 on 6.50"	25520	25520	53.53 lb.	36 pc.	1,977 lb.
RVD-10K-865-580	10,000 lb.	8 on 6.50"	382A	25520	81.10 lb.	27 pc.	2,240 lb.
BD-10K-865	10,000 lb.	N/A	BRAKE DRUM ONLY	N/A	47.30 lb.	54 pc.	2,604 lb.
BD-10K-SHT-865	10,000 lb.	N/A	BRAKE DRUM ONLY	N/A	38.10 lb.	54 pc.	2,106 lb.
RVD-12K-865-580	12,000 lb.	8 on 6.50"	3920	28622	95.10 lb.	27 pc.	2,618 lb.
RVD-16K-8275-M22	16,000 lb.	8 on 275mm	3920	28622	136.30 lb.	18 pc.	2,503 lb.
BD-12K/16K-865	16,000 lb.	N/A	BRAKE DRUM ONLY	N/A	61.00 lb.	30 pc.	1,880 lb.

Idler Hubs

MEDIUM DUTY



10K, 8 on 6.5"



16K, 8 on 275mm

PART #	DESCRIPTION				UNIT WEIGHT	CASE QTY.	CASE WEIGHT
	AXLE CAP.	BOLT DIA.	INNER RACE	OUTER RACE			
RVI-8K-865-580	8,000 lb.	8 on 6.50"	25520	02420	18.80 lb.	125 pc.	2,400 lb.
RVI-8K-865-916	8,000 lb.	8 on 6.50"	25520	02420	18.25 lb.	125 pc.	2,331 lb.
RVI-10K-865-580	10,000 lb.	8 on 6.50"	382A	25520	33.00 lb.	64 pc.	1,525 lb.
RVI-10KSHT-865-580	10,000 lb.	8 on 6.50"	382A	25520	27.30 lb.	54 pc.	1,525 lb.
RVI-12K-865-580	12,000 lb.	8 on 6.50"	3920	28622	33.14 lb.	48 pc.	1,641 lb.
RVI-16K-8275-M22	16,000 lb.	8 on 275mm	3920	28622	74.39 lb.	36 pc.	2,728 lb.

ADDITIONAL SPECS

- 8K studs (-916) are 9/16" - 18 x 2.30" and (-580) 5/8" - 18 x 2.75" with REACH compliant clear chromate plated per ASTM B633 Type III Class SC3
- 10K and 12K studs are 5/8" - 18" x 3.44" with REACH compliant zinc plated finish
- Brake DIM to Idler Hub assembly fastener FA-183536 is 1/2" - 13 x 1.50" with hex head flange in plain finish
- 16K studs are M22 x 1.50" x 4.80" with REACH compliant zinc plated finish
- All components are manufactured and assembled in ISO/TS-16949 registered facility. ASTM test bar method
- Recommended assembly installation torque for FA-183536 is 90-110 ft-lbs..

The specifications and dimensions above are for reference only.

BRAKE DRUMS & IDLER HUBS

Idler Hubs

LIGHT DUTY



PART #	PACKAGED PARTS KIT #	DESCRIPTION				UNIT WEIGHT	CASE QUANTITY	CASE WEIGHT
		AXLE CAPACITY	BOLT DIAM.	INNER RACE	OUTER RACE			
RVI-BT-4400	PP-RVIK-1 PP-RVIK-1PG PP-RVIK-11 (BT8) PP-RVIK-11PG	2,500 lb. 2,500 lb. 2,000 lb. 2,000 lb.	4 on 4.00"	L-44610	L-44610	5.50 lb.	294 pc.	1,649 lb.
RVI-BT-5450	PP-RVIK-2 PP-RVIK-2PG PP-RVIK-12 (BT8) PP-RVIK-12PG	2,500 lb. 2,500 lb. 2,000 lb. 2,000 lb.	5 on 4.50"	L-44610	L-44610	5.50 lb.	680 pc.	1,649 lb.
RVI-U-5450	PP-RVIK-3 PP-RVIK-3PG	3,500 lb.	5 on 4.50"	L-68111	L-44610	7.25 lb.	216 pc.	1,570 lb.
RVI-U-5450-LF	N/A	3,500 lb.	5 on 4.50"	L-68111	L-44610	7.75 lb.	216 pc.	1,649 lb.
RVI-U-5475	PP-RVIK-4 PP-RVIK-4PG	3,500 lb.	5 on 4.75"	L-68111	L-44610	7.50 lb.	216 pc.	1,570 lb.
RVI-U-5500	PP-RVIK-5 PP-RVIK-5PG	3,500 lb.	5 on 5.00"	L-68111	L-44610	7.50 lb.	216 pc.	1,570 lb.
RVI-U-5550	PP-RVIK-6 PP-RVIK-6PG	3,500 lb.	5 on 5.50"	L-68111	L-44610	8.20 lb.	180 pc.	1,519 lb.
RVI-U-6550	PP-RVIK-7 PP-RVIK-7PG	3,500 lb.	6 on 5.50"	L-68111	L-44610	8.30 lb.	180 pc.	1,540 lb.
RVI-H-655	PP-RVIK-8 PP-RVIK-8PG	6,000 lb.	6 on 5.50"	25520	15245	11.55 lb.	150 pc.	1,780 lb.
RVI-H-865	PP-RVIK-9 PP-RVIK-9PG	7,000 lb.	8 on 6.50"	25520	14276	14.60 lb.	125 pc.	1,875 lb.

ADDITIONAL SPECS

- Manufactured to automotive standards in ISO/TS-16949 registered factory
- All studs are 1/2" - 20 with zinc plating. (RVI-H-865-916 studs are 9/16" - 18)
- Mobile Home Idler Hub includes Rim Clamps & 9/16" -18 Bolts
- ASTM test bar method used to monitor tensile strength
- Hubs are chemically cleaned and painted black in electrostatic booth
- Mobile Home Idler includes rim clamps and bolts
- LF= Large Hub Face, 6.5" WF allowing for use with larger 13"-15" wheels
- See Packaged Parts on pg 76

**OPTIONAL PRE-GREASED
DRUMS & HUBS**

Galvanized Idler Hubs

LIGHT DUTY



PART #	DESCRIPTION				UNIT WEIGHT	CASE QUANTITY	CASE WEIGHT
	AXLE CAPACITY	BOLT DIAM.	INNER RACE	OUTER RACE			
RVI-BT-4400-HDG	2,000 lb.	4 on 4.00"	L-44610	L-44610	6.50 lb.	294 pc.	1,649 lb.
RVI-BT-5450-HDG	2,500 lb.	5 on 4.50"	L-44610	L-44610	7.48 lb.	180 pc.	7.50 lb.
RVI-U-5450-HDG	3,500 lb.	5 on 4.50"	L-68111	L-44610	7.50 lb.	216 pc.	4,380 lb.
RVI-U-5475-HDG	3,500 lb.	5 on 4.75"	L-68111	L-44610	7.50 lb.	216 pc.	3,695 lb.
RVI-U-5500-HDG	3,500 lb.	5 on 5.00"	L-68111	L-44610	7.50 lb.	216 pc.	3,695 lb.
RVI-U-5550-HDG	3,500 lb.	5 on 5.50"	L-68111	L-44610	9.45 lb.	180 pc.	4,235 lb.
RVI-U-6550-HDG	3,500 lb.	6 on 5.50"	L-68111	L-44610	9.60 lb.	180 pc.	3,110 lb.
RVI-H-655-HDG	6,000 lb.	6 on 5.50"	25520	15245	13.80 lb.	150 pc.	4,310 lb.
RVI-H-655-HDG-LS	6,000 lb.	6 on 5.50"	25520	15245	13.80 lb.	150 pc.	4,350 lb.
RVI-H-865-HDG	7,000 lb.	8 on 6.50"	25520	14276	17.10 lb.	125 pc.	3,420 lb.
RVI-H-865-HDG-LS	7,000 lb.	8 on 6.50"	25520	14276	17.10 lb.	125 pc.	3,425 lb.
RVI-H-865-916-HDG	7,000 lb.	8 on 6.50"	25520	14276	17.10 lb.	125 pc.	3,425 lb.

ADDITIONAL SPECS

- Manufactured to automotive standards in ISO/TS-16949 registered factory
- All studs are 1/2" - 20 with zinc plating. (RVI-H-865-916-HDG studs are 9/16" - 18)
- ASTM test bar method used to monitor tensile strength
- LS= Long Studs, 1/2"-20 x 2.625", for stronger clamping force and better wheel retention

Electric Brakes

Our electric brakes use SAE rated friction material and are manufactured to automotive standards in ISO/TS-16949 registered factory. Our 3.5K-7K are CSA compliant components.

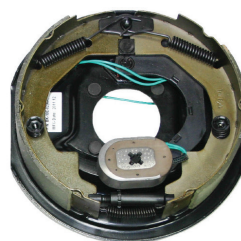

10" x 2 1/4"

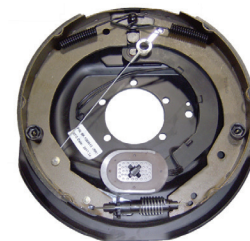

12" x 2" Self-Adjusting

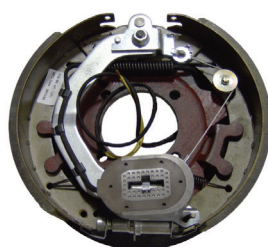

8K, 12 1/4" x 3 3/8"

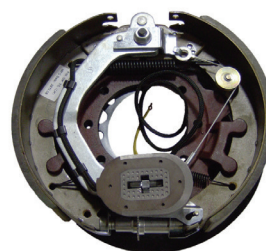

10K, 12 1/4" x 3 3/8"

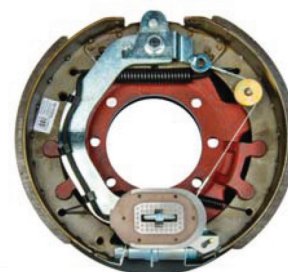

12K/16K, 12 1/4" x 5"

PART #	PACKAGED PARTS KIT #	DESCRIPTION	AXLE CAP.	UNIT WT.	CASE QTY.
BK-7E-01/02		LH/RH, 7" x 1-1/4" Assembly	2,200 lb.	4.10 lb.	420 pc.
BK-10E-01/02	PP-BKK-1 (LH) PP-BKK-2 (RH)	LH/RH, 10" x 2-1/4" Assembly	3,500 lb.	9.60 lb.	168 pc.
BK-10E-01SA/02SA	PP-BKK-3 (LH) PP-BKK-4 (RH)	LH/RH, 10" x 2-1/4" Self-Adjusting Assembly	3,500 lb.	9.88 lb.	168 pc.
BK-10E4K-01-02		LH/RH, 10" x 2-1/4" Assembly, 4,400 lb.	4,400 lb.	9.60 lb.	162 pc.
BK-10E4K-01SA/02SA		LH/RH, 10" x 2-1/4" Self-Adjusting Assembly, 4,400 lb.	4,400 lb.	9.60 lb.	162 pc.
BK-10E-01P/02P		LH/RH, 10" x 2-1/4" Assembly, Park	4,400 lb.	10.00 lb.	168 pc.
BK-12E-01/02	PP-BKK-5 (LH) PP-BKK-6 (RH)	LH/RH, 12" x 2" Assembly	7,000 lb.	14.80 lb.	126 pc.
BK-12E-01SA/02SA	PP-BKK-7 (LH) PP-BKK-8 (RH)	LH/RH, 12" x 2" Self-Adjusting Assembly	7,000 lb.	14.80 lb.	126 pc.
BK-12E-01P/02P		LH/RH, 12" x 2" Assembly, Park	7,000 lb.	14.80 lb.	126 pc.
BK-8KE-01/02	PP-BKK-21 (LH) PP-BKK-22 (RH)	LH/RH, 8K, 12-1/4" x 3-3/8" Assembly	8,000 lb.	18.78 lb.	90 pc.
BK-10KE-01/02	PP-BKK-23 (LH) PP-BKK-24 (RH)	LH/RH, 10K, 12-1/4" x 3-3/8" Assembly, Self-Adjusting, 7 Hole	10,000 lb.	18.78 lb.	90 pc.
BK-10KEQ-01/02		LH/RH, 10K, 12-1/4" x 3-3/8", Self-Adjusting, 5 Hole w/Bolts	10,000 lb.	17.60 lb.	90 pc.
BK-10KEHD-01/02		LH/RH, 10K, 12-1/4" x 4", Self-Adjusting, 7 Hole	10,000 lb.	19.38 lb.	81 pc.
BK-12KE-01/02		LH/RH, 12K/16K, 12-1/4" x 5", Self-Adjusting, 7 Hole	12,000-16,000 lb.	19.80 lb.	63 pc.

PART #	DESCRIPTION	UNIT WEIGHT	CASE QTY.	CASE WT.
BK-12E-MHL-01/02	LH/RH, 12" x 2", Mobile Home, Weld-On	8.40 lb.	180/240	1,570 lb./2,080 lb.

ADDITIONAL SPECS

- Magnet tested 100% for pull force and conductivity
- 10" and 12" Brakes are recognized as a component for assembly with the complete running gear as described in QAI listing REC625-1
- See Packaged Parts on pg 77

Hydraulic Brakes

Our hydraulic brakes are composed of aluminum wheel cylinders stainless steel springs and feature Dacromet*, an inorganic zinc rich coating designed to protect from rust.



Uni-Servo E-coat

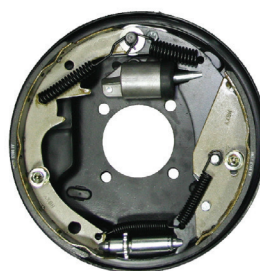

Free-Backing E-coat

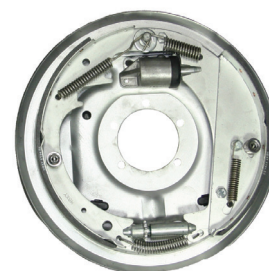

Free-Backing Dacromet

PART #	PACKAGED PARTS KIT #	DESCRIPTION	AXLE CAP.	UNIT WT.	CASE QTY.
BK-18787	PP-BKK-9	RH, 10" Uni-Servo, E-coat	3,500 lb.	8.49 lb.	156 pc.
BK-18788	PP-BKK-10	LH, 10" Uni-Servo, E-coat	3,500 lb.	8.49 lb.	156 pc.
BK-40715	PP-BKK-11	RH, 10" Free Backing, E-coat	3,500 lb.	9.59 lb.	156 pc.
BK-40716	PP-BKK-12	LH, 10" Free Backing, E-coat	3,500 lb.	9.59 lb.	156 pc.
BK-40715X	PP-BKK-13	RH, 10" Free Backing, Dacromet	3,500 lb.	9.59 lb.	156 pc.
BK-40716X	PP-BKK-14	LH, 10" Free Backing, Dacromet	3,500 lb.	9.59 lb.	156 pc.
BK-23510	PP-BKK-15	RH, 12" Uni-Servo, E-coat	7,000 lb.	13.34 lb.	117 pc.
BK-23511	PP-BKK-16	LH, 12" Uni-Servo, E-coat	7,000 lb.	13.34 lb.	117 pc.
BK-42028	PP-BKK-17	RH, 12" Free Backing, E-coat	7,000 lb.	14.66 lb.	117 pc.
BK-42029	PP-BKK-18	LH, 12" Free Backing, E-coat	7,000 lb.	14.66 lb.	117 pc.
BK-42028X	PP-BKK-19	RH, 12" Free Backing, Dacromet	7,000 lb.	14.66 lb.	117 pc.
BK-42029X	PP-BKK-20	LH, 12" Free Backing, Dacromet	7,000 lb.	14.66 lb.	117 pc.
BK-8KH-02		RH, 8K, 12-1/4" x 3-3/8", Self-Adjusting, 4 Hole	8,000 lb.	18.30 lb.	90 pc.
BK-8KH-01		LH, 8K, 12-1/4" x 3-3/8", Self-Adjusting, 4 Hole	8,000 lb.	18.30 lb.	90 pc.
BK-10KH-02		RH, 10K, 12-1/4" x 3-3/8", Self-Adjusting, 7 Hole	10,000 lb.	18.30 lb.	90 pc.
BK-10KH-01		LH, 10K, 12-1/4" x 3-3/8", Self-Adjusting, 7 Hole	10,000 lb.	18.30 lb.	90 pc.
BK-12KH-02		RH, 12K-16K, 12-1/4" x 5", Self-Adjusting, 7 Hole	12,000-16,000 lb.	20.94 lb.	63 pc.
BK-12KH-01		LH, 12K-16K, 12-1/4" x 5", Self-Adjusting, 7 Hole	12,000-16,000 lb.	20.94 lb.	63 pc.

ADDITIONAL SPECS

- SAE friction material
- All components are manufactured utilizing industry recognized materials and/or substitutes and assembled in ISO/TS-16949 registered facility
- Magnets tested 100% for pull force and conductivity
- Fully integrated manufacturing and assembly operations
- Detailed control plans utilized in manufacturing
- Dacromet coating is only available in free backing brakes
- See Packaged Parts on pg 77

TruRyde Disc Brake Kits

3.5K

5 LUG 1/2" STUDS, INTEGRATED ROTOR
ZINC OR E-COAT FINISH



Zinc



E-coat

PART #	DESCRIPTION
DBI-3.5K-TR-ECOAT (Complete Kit)	TruRyde 3.5K Disc Kit, (2) Black E-Coat Integrated Rotors, and (2) Clear Zinc Calipers w/ Pads
DBI-3.5K-TR-ZINC (Complete Kit)	TruRyde 3.5K Disc Kit, (2) Clear Zinc Integrated Rotors, and (2) Clear Zinc Calipers w/ Pads
RTR/HUB-975-TR-ECOAT	9.75" RTR/HUB, 5-Lug Integrated, 1/2" WS, E-Coat
RTR/HUB-975-TR-ZINC	9.75" RTR/HUB, 5-Lug Integrated, 1/2" WS, Zinc
CALP-3-6K-TR-ZINC	3-6K Caliper, Zinc w/ Pads

6K

6 LUG 1/2" STUDS, INTEGRATED ROTOR
ZINC OR E-COAT FINISH



Zinc



E-coat

PART #	DESCRIPTION
DBI-6K-TR-ECOAT (Complete Kit)	TruRyde 6K Disc Kit, (2) Black E-Coat Integrated Rotors, (2) Top Mount E-Coat Brackets, and (2) Clear Zinc Calipers w/ Pads
DBI-6K-TR-ZINC (Complete Kit)	TruRyde 6K Disc Kit, (2) Clear Zinc Integrated Rotors, (2) Top Mount Clear Zinc Brackets, and (2) Clear Zinc Calipers w/ Pads
DBI-6K-TR-SM-ECOAT (Complete Kit)	TruRyde 6K Disc Kit, (2) Black E-Coat Integrated Rotors, (2) Side Mount E-Coat Brackets, and (2) Clear Zinc Calipers w/ Pads
DBI-6K-TR-SM-ZINC (Complete Kit)	TruRyde 6K Disc Kit, (2) Clear Zinc Integrated Rotors, (2) Side Mount Clear Zinc Brackets, and (2) Clear Zinc Calipers w/ Pads
RTR/HUB-1177-TR-ECOAT	11.77" RTR/HUB, 6-Lug Integrated, 1/2" WS, E-Coat
RTR/HUB-1177-TR-ZINC	11.77" RTR/HUB, 6-Lug Integrated, 1/2" WS, Zinc
CALP-3-6K-TR-ZINC	3-6K Caliper, Zinc w/ Pads
DBB-6K-TR-ECOAT	6K Bracket, E-Coat, Top Mount
DBB-6K-TR-ZINC	6K Bracket, Zinc, Top Mount
DBB-6K-TR-SM-ECOAT	6K Bracket, E-Coat, Side Mount
DBB-6K-TR-SM-ZINC	6K Bracket, Zinc, Side Mount

ADDITIONAL SPECS

- Non-handed Caliper; less inventory requirement
- Inlet & Outlet Ports at 45 degree angle; more efficient bleeding system
- Vented Rotor; better airflow for a cooler unit, allows water to escape

*One kit required per axle.

DeeMaxx Disc Brake Kits

3.5K

5 LUG 1/2" STUDS, INTEGRATED OR SLIP OVER ROTOR

PART #	DESCRIPTION
DBI-3.5K-MAXX RTR/HUB-102-MAXX CALP-3-6K-MAXX DBB-3.5KI-MAXX CALP-3-6K-BRAKE PAD	Integrated Kit Contains Rotor/Hubs, Calipers And Brackets For One Axle
DBSO-3.5K-MAXX RTR-109-MAXX CALP-3-6K-MAXX DBB-3.5K-MAXX CALP-3-6K-BRAKE PAD	Slip Over Kit Contains Rotor/Hubs, Calipers And Brackets For One Axle

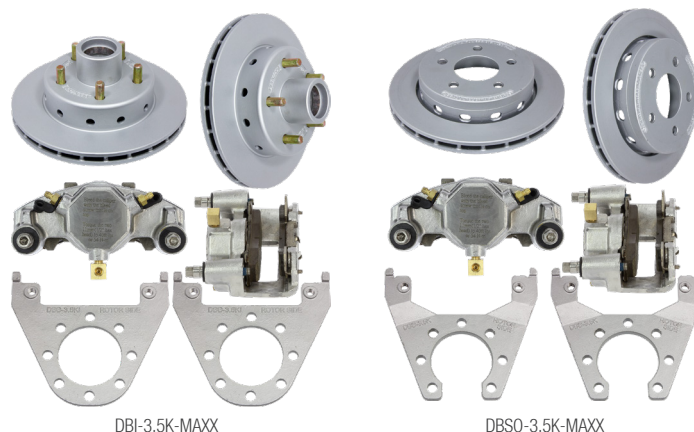

DBI-3.5K-MAXX

DBSO-3.5K-MAXX

6K

6 LUG 1/2" STUDS, INTEGRATED OR SLIP OVER ROTOR

PART #	DESCRIPTION
DBI-6K-MAXX RTR/HUB-120-MAXX CALP-3-6K-MAXX DBB-6K-MAXX CALP-3-6K-BRAKE PAD	Integrated Kit Contains Rotor/Hubs, Calipers And Brackets For One Axle
DBSO-6K-MAXX RTR-120-MAXX CALP-3-6K-MAXX DBB-6K-MAXX CALP-3-6K-BRAKE PAD	Slip Over Kit Contains Rotor/Hubs, Calipers And Brackets For One Axle

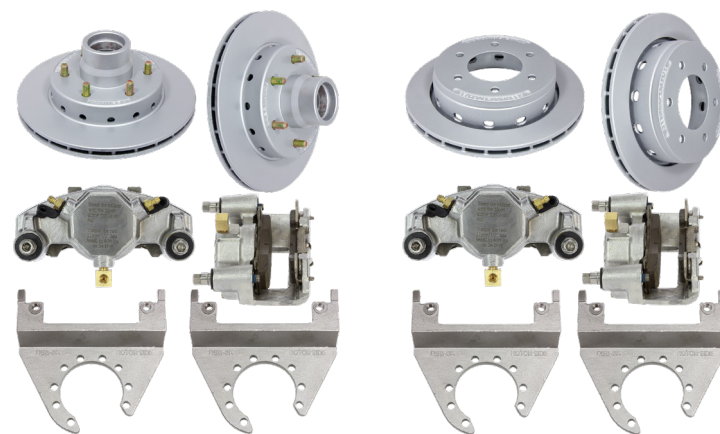

DBI-6K-MAXX

DBSO-6K-MAXX

7K

8 LUG 1/2", 9/16", 5/8" STUDS, INTEGRATED OR SLIP OVER ROTOR

PART #	DESCRIPTION
DBI-7K-MAXX RTR/HUB-131-7K-MAXX CALP-7-8K-MAXX DBB-7K-MAXX CALP-7-8K-BRAKE PAD	Integrated Kit Contains Rotor/Hubs, Calipers And Brackets For One Axle
DBSO-7K-MAXX RTR-131-7K-MAXX CALP-7-8K-MAXX DBB-7K-MAXX CALP-7-8K-BRAKE PAD	Slip Over Kit Contains Rotor/Hubs, Calipers And Brackets For One Axle
DBI-7K-9-MAXX RTR/HUB-131-8K-.56-MAXX CALP-7-8K-MAXX DBB-7K-MAXX CALP-7-8K-BRAKE PAD	Integrated Kit Contains Rotor/Hubs, Calipers And Brackets For One Axle
DBI-7K-10-MAXX RTR/HUB-131-8K-.62-MAXX CALP-7-8K-MAXX DBB-7K-MAXX CALP-7-8K-BRAKE PAD	Integrated Kit Contains Rotor/Hubs, Calipers And Brackets For One Axle

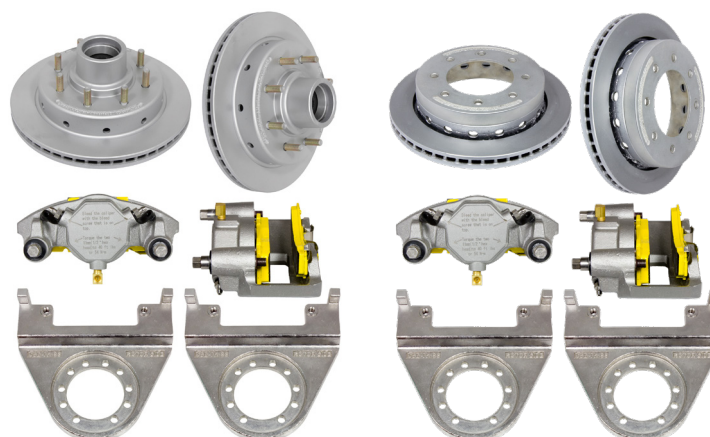

DBI-7K-MAXX

DBSO-7K-MAXX

*One kit required per axle.

**Optional Yellow Zinc Plated finish is available by replacing "MAXX" with "GOLD" on the kit part number and caliper part number

8K

8 LUG 9/16" STUDS, INTEGRATED OR SLIP OVER ROTOR
 8 LUG 5/8" STUDS, INTEGRATED OR SLIP OVER ROTOR
 MAXX OR GOLD FINISH

INTEGRATED NON-THREADED (GREASE)

PART #	DESCRIPTION
DBI-8KD9-NT-MAXX RTR/HUB-131-8KNT-.56-MAXX CALP 7-8K-MAXX w/HH PADS DBB-8KD-MAXX	One Axle Set Of Integral 8,000lb Maxx Coating Disc Brakes. 9/16" Studs
DBI-8KD10-NT-MAXX RTR/HUB-131-8KNT-.62-MAXX CALP 7-8K-MAXX w/HH PADS DBB-8KD-MAXX	One Axle Set Of Integral 8,000lb Maxx Coating Disc Brakes. 5/8" Studs
DBI-8KA10-NT-MAXX RTR/HUB-131-8KNT-.62-MAXX CALP 7-8K-MAXX w/HH PADS DBB-8KA-MAXX	One Axle Set Of Integral 8,000lb Maxx Coating Disc Brakes. 5/8" Studs

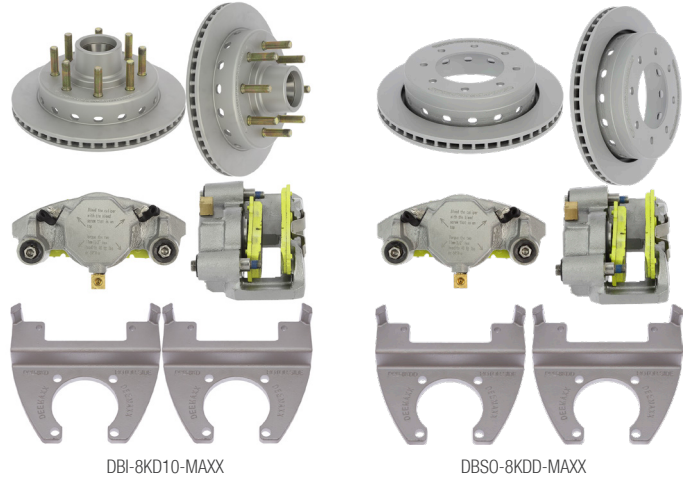

INTEGRATED THREADED (OIL)

PART #	DESCRIPTION
DBI-8KD9-T-MAXX RTR/HUB-131-8KT-.56-MAXX CALP 7-8K-MAXX w/HH PADS DBB-8KD-MAXX	One Axle Set Of Integral 8,000lb Maxx Coating Disc Brakes. 9/16" Studs
DBI-8KD10-T-MAXX RTR/HUB-131-8KT-.62-MAXX CALP 7-8K-MAXX w/HH PADS DBB-8KD-MAXX	One Axle Set Of Integral 8,000lb Maxx Coating Disc Brakes. 5/8" Studs

SLIP OVER

PART #	DESCRIPTION
DBSO-8KDD-MAXX RTR/HUB-131-8K-MAXX CALP 7-8K-MAXX w/HH PADS DBB-8KDD-MAXX	One Axle Set Of Slip Over 8,000lb Maxx Coating Disc Brakes. Can Be Used With 5/8" Or 9/16" Studs *Must Use Dexter Or Deemaxx Disc Idler Hub
DBSO-8KA-MAXX RTR/HUB-131-8K-MAXX CALP 7-8K-MAXX w/HH PADS DBB-8KA-MAXX	One Axle Set Of Slip Over 8,000lb Maxx Coating Disc Brakes. Can Be Used With 5/8" Or 9/16" Studs *Must Use Axis/Alko Or Rockwell Disc Idler Hub

Single Wheel Disc Brakes

10-12K

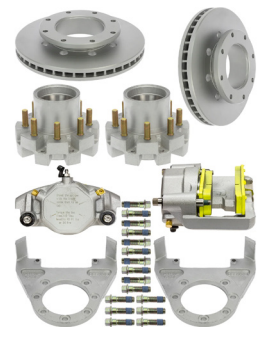
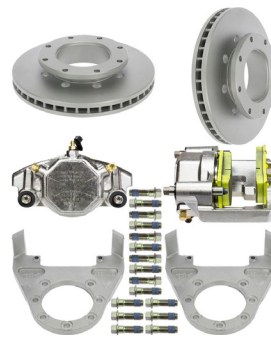
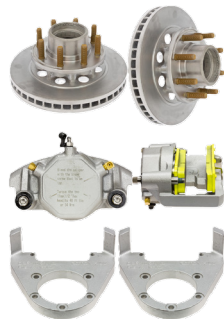
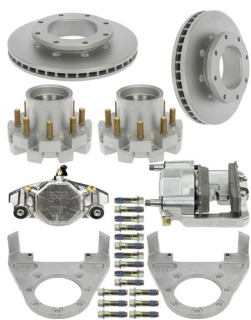

One (Axle) Set Of Integral 10,000 lb Maxx Disc Brakes For Dexter/Lippert Spindle
 Includes Maxx Integral 13" Rotor, Maxx Caliper W Sm Pads, Maxx Bracket & Hub Mounting Bolts
 * Fits 16" Single Wheel Application W/ 5/8" Wheel Studs - Uses 387A Inner/25580 Outer Bearings.

One (Axle) Set Of Integral 10,000 lb Maxx Disc Brakes For Alko/Quality #99 Spindle
 Includes Maxx Integral 13" Rotor, Maxx Caliper W Pads, Maxx Bracket & Hub Mounting Bolts * Fits 17.5" Single Wheel Application W/ 5/8" Wheel Studs - Uses 28580 Inner /25580 Outer Bearings

One (Axle) Set Of 12,000 lb Maxx Disc Brakes For Dexter/Lippert #14T Spindle
 Includes 16-Rtr-Bolt 1/2-13 X 1.5" For 13" Rtr/Sp, Maxx Caliper W/Pads, Maxx Bracket And Hub Mounting Bolts
 Uses 3984 Inner/28682 Outer Bearings

One (Axle) Set Of Integral 12,000 lb Maxx Disc Brakes For Dexter/Lippert Spindle
 Includes Maxx Integral 13" Rotor, Maxx Caliper W Sm Pads, Maxx Bracket & Hub Mounting Bolts
 Uses 3984 Inner/28682 Outer Bearings.

Dual Wheel Disc Brakes

9-16K

PART #	DESCRIPTION
DBI-10KDL-DW-MAXX	One Axle set of Integral 10,000 lb. Maxx Coating Disc Brakes for Dexter/Lippert Spindle With 5.25" Inner Bearing shoulder to Brake Flange. Use 387A Inner / 25580 Outer Bearing Includes Hub, 32-RTR-Bolt 1/2-13 x 1.5" for 13" Rotor/Sp, Zinc Caliper w/ SM Pads, AND Zinc Bracket (7 Bolt) *Fits 16" Dual Wheel Wheel Application w/ 5/8" Wheel Studs
DBI-12KDL-DW-MAXX	One Axle set of Integral 12,000 lb. Maxx Coating Disc Brakes for Dexter/Lippert Spindle With 5.25" Inner Bearing shoulder to Brake Flange. Use 3984 Inner / 28682 Outer Bearing Includes Hub-12KDL, 32-RTR-Bolt 1/2-13 x 1.5" for 13" Rotor/Sp, Zinc Caliper w/ Black SM Pads, AND Zinc Bracket (7 Bolt) *Fits 16" Dual Wheel Wheel Application w/ 5/8" Wheel Studs
DBI-16KDL-DW-MAXX	One Axle set of Integral 16,000 lb. Maxx Coating Disc Brakes for Dexter/Lippert Spindle. Use 3984 Inner / 28682 Outer Bearing Includes Hub-16KDL, 32-RTR-Bolt 1/2-13 x 1.5" for 13" Rotor/Sp, Zinc Caliper w/ Black SM Pads, and Zinc Bracket (7 Bolt) *Fits 16" Dual Wheel Application w/ M22 Wheel Studs
DBB-10-16KDL-DW-ZINC	Disc Brake Bracket for 7 hole brake flange 10-16K Dexter/Lippert Dual Wheel Axle fits 11" Rotor, Zinc Coating
CALP-10-16KDW-ZINC	Disc Brake Bracket for 10-16K Axle Dual Wheel 2 - Piston Zinc Plated with Green Semi-metallic Brake Pads
RTR-11-10-16KDL-DW-MAXX	11" Bolt-on rotor for Dexter/Lippert with (8) 1" and (8) - .530" holes Maxx fits HUB-9-16K
RTR-10-16K-BOLT	Bolt, 1/2-13 x 1.5", 6 pt Hex w/flange Grade 8 Yellow Zinc Plated 3M22352 w/Blue Loctite, Torque Bolt to Rotor at 80 ft. lb.
HUB-11-10-16KDL-DW-SPCR-MAXX	Spacer for 11" Bolt on Rotor for Dexter/Lippert with 8 - 1/2" - 13UNC-2B and 8 - .530" holes, Maxx fits Hub 9-16K
RVI-10K-865-580	8 on 6.5" 10K Dexter/Lippert Oil Hub 4.75" Pilot, 25520 (Outer) and 382A (Inner) Bearing races and (Yellow) 5/8"-18 Wheels Studs DX# 008-288-03 9-10K GD Use 387A (Inner) and 25580 (Outer) Bearing
RVI-12K-865-580	8 on 6.5" 12K Dexter/Lippert Oil Hub 4.75" Pilot, Inner Bearing 3984 Cup/Race 3920 and Outer Bearing 28682 Cup/Race 28622 DX# 008-214-10
RVI-16K-8275-M22	8 on 275 mm M22 Wheel Studs 16K Dexter/Lippert Oil Hub, Inner Bearing 3984 Cup/Race 3920 and Outer Bearing 28682 Cup, Race 28622 DX# 088-401-05

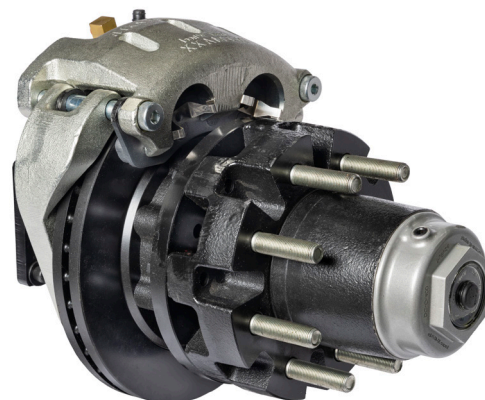

DBI-12KDL-DW-MAXX

UNIQUE BRACKET DESIGN PROVIDES TWICE AS MANY MOUNTING OPTIONS FOR CALIPER POSITION

EVERY CALIPER IS TESTED TO 2000 PSI

120° BLEEDER DESIGN

- Better bleeding
- Balanced system
- No more damaged bleeders

PASSED THE SAE J2681 BRAKE TEST

ADDITIONAL SPECS

- Fits 16" Dual Wheel or larger
- All parts are non-handed (L or R)
- Laser writing on caliper for bleeding instructions and torque specifications

High Performance Brake Lines



RUBBER BRAKE LINES						
DOT-RFL-12"	DOT-RFL-16"	DOT-RFL-18"	DOT-RFL-24"	DOT-RFL-36"	DOT-RFL-38"	DOT-RFL-60"
DOT-RFL-72"	DOT-RFL-78"	DOT-RFL-220"	DOT-RFL-240"	DOT-RFL-260"	DOT-RFL-280"	DOT-RFL-312"

STAINLESS STEEL BRAKE LINES			
DOT-SSFL-18"	DOT-SSFL-24"	DOT-SSFL-30"	DOT-SSFL-36"

BRAKE LINE ASSEMBLIES	DESCRIPTION
DOT-BF3W	3 way 3 1/16" inverted flare inlets
DOT-BF4W	4 way 3 1/16" inverted flare inlets
DOT-BF90	90 degree elbow 3/16" inverted flare inlets
DOT-BFUNION	Coupler with 3 1/16" inverted flare inlets
DOT-HMC	Hose Mount, Clamp, Neoprene Cushioned, 304 SS, .375 in. O.D. Hose
DOT-NCTIE	Black UV protected nylon, self locking axle tie with slip prevention locking to secure brake lines to axle.
DOT-SSSDS	Stainless Steel Self Drilling Screw w/ Indented Hex Washer 6mm x 24 mm Indented Hex Washer #3 drill point 2/8" Hex Head

DeeMaxx Brake Line Kits

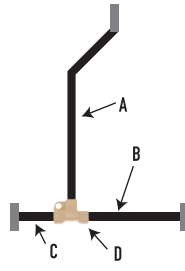

18' SINGLE AXLE BRAKE LINE KIT (DOT-SA18K)

DOT-SA18K CONTENTS:

- A - (1) 220" long flexible trailer brake line
- B - (1) 72" long flexible trailer brake line
- C - (1) 18" long flexible trailer brake line
- D - (1) Brass 3 way 'T' fitting (mounting screw included)
- (10) Brake Line Clamps 10 mounting screws included
- (6) Axle Tie Straps

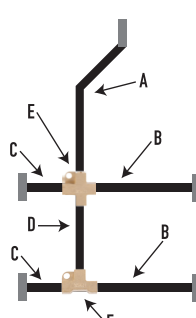
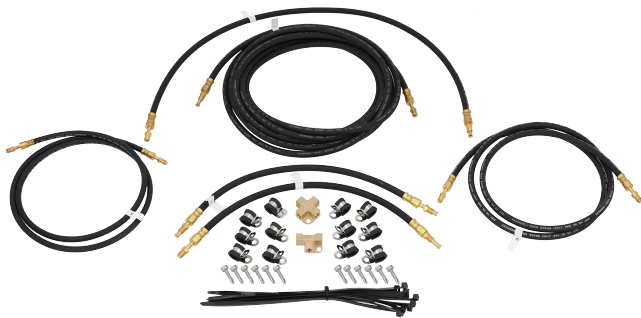

20' TANDEM AXLE BRAKE LINE KIT (DOT-TA20K)

DOT-TA20K CONTENTS

- A - (1) 240" long flexible trailer brake line
- B - (2) 72" long flexible trailer brake line
- C - (2) 18" long flexible trailer brake line
- D - (1) 36" long flexible trailer brake line
- E - (1) Brass "4 way" fitting
- F - (1) Brass 3 way 'T' fitting (mounting screw included)
- (12) Brake Line Clamps (12) mounting screws included
- (12) Axle Tie Straps

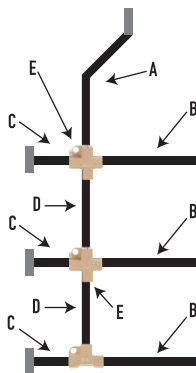

20' TRIPLE AXLE BRAKE LINE KIT (DOT-TR20K)

DOT-TR20K CONTENTS

- A - (1) 240" long flexible trailer brake line
- B - (3) 72" long flexible trailer brake line
- C - (3) 18" long flexible trailer brake line
- D - (2) 36" long flexible trailer brake line
- E - (2) Brass "4 way" fittings (mounting screws included)
- F - (1) Brass 3 way 'T' fitting (mounting screw included)
- (14) Brake Line Clamps (14) mounting screws included
- (18) Axle Tie Straps

Brake Actuators

ELECTRIC-OVER-HYDRAULIC

DeeMaxx/Deutsche Hydrapro™ developed their Hydrapro Electric Over Hydraulic (EOH) Brake Actuator with a global German hydraulic pump manufacturer with over 90 years of experience providing innovative hydraulic drive and control technologies.

Our electric-over-hydraulic brake actuator's quality and simplicity gives you the necessary reliability for a trailer braking system. In addition, it has a superior response time that delivers shorter stopping distances, which gives the driver confidence while towing. DeeMaxx is the only company that offers 360° brake line position connection,



ANODIZED, T6-GRADE EXTRUDED ALLOY HOUSING

protects from different environments

INDEPENDENTLY SEALED FLUID TANK

provides extra fluid reserves

3X LONGER LASTING DURABILITY IN EXTREME TESTING

PART #	DESCRIPTION
TR-EOHA1600X	1600 psi w/ Larger Fluid Capacity, 28.7 oz.
TR-EOHA1600	1600 psi for Disc Brakes
TR-EOHA1200	1200 psi for Drum Brakes w/ 8k or Higher Axles
TR-EOHA1000	1000 psi for Drum Brakes w/ 8k or Lower Axles



TR-EOHA1600



HIGH-POWERED DC MOTOR

with minimal moving parts for reliability

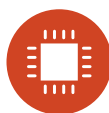

ROBUST ELECTRONICS BOARD

with protective coating for corrosion resistance



2-YEAR WARRANTY

giving you peace of mind

SURGE

PART #	DESCRIPTION
TR-AS7K-2.00-WO-DISC	7K, 2" Ball, Weld-On, Disc
TR-AS8.4K-2.00-WO-DISC	8.4K, 2" Ball, Weld-On, Disc

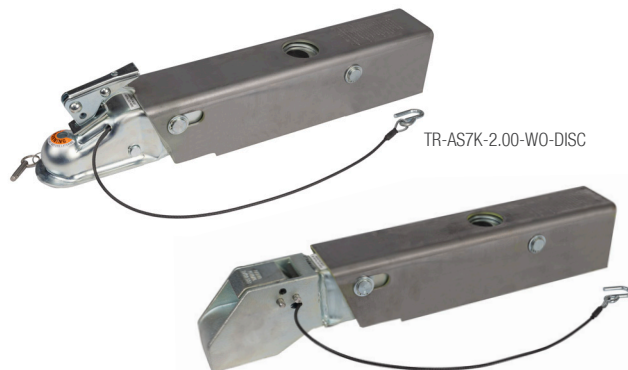

TR-AS7K-2.00-WO-DISC

TR-AS8.4K-2.00-WO-DISC

Leaf Springs

DOUBLE EYE - 1-3/4" WIDE

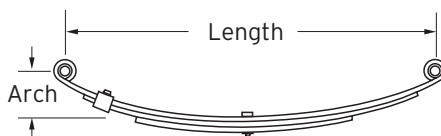

PART #	# OF LEAVES	FREE LENGTH	FREE ARCH	CAPACITY PER SPRING	BUSHING ID.	WEIGHT EACH	SKID QUANTITY	SKID WEIGHT	REFERENCE #S
DE-7216	3	20.25"	3.38"	850 lb.	9/16"	6.05 lb.	200 pc.	1,220 lb.	UNA-168, DX-720
DE-7217	3	20.38"	3.18"	1,000 lb.	9/16"	6.29 lb.	200 pc.	1,400 lb.	UNA-169, X1020
DE-7213	4	20.50"	3.38"	1,400 lb.	9/16"	9.18 lb.	200 pc.	1,860 lb.	UNA-167, 93162
DE-7220	4	23.12"	3.63"	2,500 lb.	9/16"	12.56 lb.	200 pc.	2,512 lb.	72-20
DE-726	3	23.13"	3.63"	1,250 lb.	9/16"	9.10 lb.	200 pc.	1,820 lb.	UNA-135
DE-7218	4	23.13"	3.50"	2,000 lb.	9/16"	12.40 lb.	200 pc.	2,480 lb.	UNA-170, WAH-4
DE-729	3	23.25"	3.50"	1,750 lb.	9/16"	11.00 lb.	200 pc.	2,200 lb.	UNA-216, 1724-3L
DE-93180	3	23.25"	3.00"	1,750 lb.	9/16"	9.65 lb.	250 pc.	2,460 lb.	729
DE-93183	4	23.25"	3.13 "	2,900 lb.	9/16"	12.90 lb.	200 pc.	2,580 lb.	
DE-113	3	23.50"	3.50"	1,000 lb.	9/16"	9.30 lb.	200 pc.	1,860 lb.	UNA-113, 545-3L
DE-114	4	23.50"	3.50"	1,400 lb.	9/16"	10.70 lb.	330 pc.	3,915 lb.	UNA-114, 545-4L
DE-7227	6	24.88"	3.38"	3,500 lb.	9/16"	18.30 lb.	150 pc.	2,738 lb.	UNA-222, 1769
DE-7226	4	25.13"	3.13"	3,000 lb.	9/16"	15.40 lb.	200 pc.	3,080 lb.	UNA-221, 93115
DE-SW2	2	25.25"	3.00"	1,000 lb.	9/16"	9.43 lb.	250 pc.	2,360 lb.	PR-2
DE-7222	3	25.25"	3.18"	1,250 lb.	9/16"	9.60 lb.	200 pc.	1,920 lb.	UNA-219, SW3B
DE-7223	3	25.25"	3.00"	1,500 lb.	9/16"	11.00 lb.	200 pc.	2,200 lb.	UNA-217
DE-SW3	3	25.25"	3.00"	1,750 lb.	9/16"	11.70 lb.	200 pc.	2,340 lb.	UNA-220, 1762, 72-24
DE-7242	4	25.25"	3.00"	1,750 lb.	9/16"	11.70 lb.	330 pc.	3,915 lb.	UNA-212, SW4B
DE-SW4B	4	25.25"	3.00"	1,750 lb.	9/16"	11.70 lb.	200 pc.	2,340 lb.	93184, 7242, DE-1723124
DE-7224	3	25.25"	3.00"	2,000 lb.	9/16"	12.30 lb.	200 pc.	2,458 lb.	UNA-220, 1762, SW3
DE-7278	4	25.25"	3.13 "	2,200 lb.	9/16"	11.47 lb.	270 pc.	3,150 lb.	72-78
DE-7225	4	25.25"	3.00"	2,500 lb.	9/16"	15.10 lb.	200 pc.	3,014 lb.	UNA-218, 1763, SW4
DE-SW4	4	25.25"	3.00"	2,500 lb.	9/16"	13.80 lb.	288 pc.	2,760 lb.	UNA-218, 1763, 72-25
DE-1764	5	25.25"	3.00"	2,900 lb.	9/16"	17.00 lb.	125 pc.	2,125 lb.	UNA-111, 1764, SW5
DE-SW5	5	25.25"	3.00"	2,950 lb.	9/16"	16.30 lb.	240 pc.	2,038 lb.	UNA-111, 1764
DE-7240	1	25.25"	3.00"	3,000 lb.	9/16"	8.70 lb.	440 pc.	3,826 lb.	UNA-115, 72-40, TE-30
DE-SW6	6	25.25"	3.00"	3,500 lb.	9/16"	19.10 lb.	210 pc.	2,388 lb.	UNA-223, SW6
DE-93102	3	26.00"	3.00"	1,500 lb.	9/16"	11.04 lb.	200 pc.	2,208 lb.	SW-3F, PR-3
DE-93103	4	26.00"	3.13"	2,000 lb.	9/16"	13.92 lb.	200 pc.	2,784 lb.	SW4
DE-AWS4	4	26.00"	4.25"	2,000 lb.	9/16"	14.00 lb.	200 pc.	2,798 lb.	UNA-051, AWS4
DE-93163	5	26.00"	3.13 "	2,500 lb.	9/16"	16.68 lb.	150 pc.	2,502 lb.	SW5, PR-5
DE-AWS5	5	26.00"	4.25"	2,500 lb.	9/16"	17.10 lb.	125 pc.	2,134 lb.	UNA-052, AWS5
DE-SW626	6	26.00"	3.75"	2,700 lb.	9/16"	17.02 lb.	150 pc.	2,553 lb.	
DE-93160	6	26.00"	3.13 "	3,000 lb.	9/16"	18.90 lb.	150 pc.	2,835 lb.	SW6, PR-6
DE-AWS6	6	26.00"	4.25"	3,000 lb.	9/16"	20.30 lb.	125 pc.	2,538 lb.	UNA-053, AWS6
DE-AWS7	7	26.00"	4.25"	3,500 lb.	9/16"	23.40 lb.	130 pc.	3,043 lb.	UNA-054, AWS7
DE-26350	2	26.00"	4.13"	350 lb.	9/16"	7.00 lb.	300 pc.	1,400 lb.	UNA-121, 26-350, AS2
DE-AWS8	8	26.00"	4.25"	4,000 lb.	9/16"	27.20 lb.	125 pc.	3,400 lb.	UNA-055, AWS8
DE-26500	3	26.00"	4.12"	500 lb.	9/16"	9.10 lb.	300 pc.	1,820 lb.	UNA-122, 25-500, AS3
DE-33612	3	27.00"	2.88"	1,000 lb.	9/16"	10.10 lb.	200 pc.	2,022 lb.	UNA-141, 20327
DE-33613	4	27.00"	2.88"	2,100 lb.	9/16"	14.00 lb.	200 pc.	2,800 lb.	UNA-210, 35427
DE-45527	5	27.00"	2.75"	2,250 lb.	9/16"	17.30 lb.	125 pc.	2,158 lb.	UNA-234, 45527
DE-33617	6	27.00"	3.25"	3,000 lb.	9/16"	22.30 lb.	125 pc.	2,788 lb.	UNA-142, 60627
DE-33611	3	27.00"	3.50"	750 lb.	1/2"	9.10 lb.	200 pc.	1,820 lb.	UNA-144, 15327/ DE3L750
DE-7234	3	30.00"	4.38"	1,250 lb.	9/16"	13.12 lb.	175 pc.	2,296 lb.	72-34

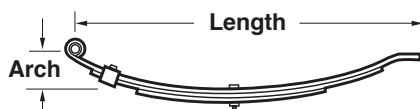

SLIPPER FLAT - 1-3/4" WIDE

PART #	# OF LEAVES	FREE LENGTH	FREE ARCH	CAP. PER SPRING	BUSHING ID.	WEIGHT EACH	SKID QTY.	SKID WEIGHT	REFERENCE #S
SF-047	3	24.50"	4.12"	1,675 lb.	9/16"	11.00 lb.	200 pc.	2,200 lb.	UNA-047
SF-BT25-12	4	25.00"	3.50"	1,250 lb.	9/16"	9.60 lb.	250 pc.	2,450 lb.	
SF-BT25-15	3	25.00"	3.50"	1,500 lb.	9/16"	10.47 lb.	300 pc.	3,191 lb.	
SF-BT25-22	3	25.00"	3.50"	1,750 lb.	9/16"	10.47 lb.	250 pc.	2,668 lb.	
SF-BT25-30	4	25.00"	3.50"	2,350 lb.	9/16"	12.90 lb.	200 pc.	2,630 lb.	
SF-BT25-25	3	25.00"	3.50"	2,500 lb.	9/16"	9.56 lb.	200 pc.	1,912 lb.	
SF-BT25-9	3	25.00"	3.50"	950 lb.	9/16"	7.55 lb.	250 pc.	1,940 lb.	
SF-015	4	25.12"	5.00"	1,000 lb.	9/16"	9.50 lb.	250 pc.	2,375 lb.	UNA-015
SF-013	2	25.12"	5.00"	500 lb.	9/16"	5.80 lb.	250 pc.	1,450 lb.	UNA-013
SF-014	3	25.12"	5.00"	750 lb.	9/16"	7.90 lb.	250 pc.	1,975 lb.	UNA-014
SF-WD2 = SF-432110	2	30.00"	4.88"	1,000 lb.	9/16"	10.03 lb.	300 pc.	3,059 lb.	UNA-038, WD-2
SF-WF3 = SF-433115	3	30.00"	4.88"	1,500 lb.	9/16"	11.89 lb.	200 pc.	2,428 lb.	UNA-039, WF-3
SF-039	3	30.00"	4.88"	1430 lb.	9/16"	12.13 lb.	200 pc.	2,426 lb.	EMCO-039
SF-WG5 = SF-434118	5	30.00"	4.88"	2,400 lb.	9/16"	18.13 lb.	150 pc.	2,770 lb.	UNA-040N, WG-5
SF-BT25-6	2	30.00"	3.50"	600 lb.	9/16"	5.95 lb.	250 pc.	1,540 lb.	
SF-WG4 = SF-434117	4	30.25"	4.88"	2,000 lb.	9/16"	16.37 lb.	200 pc.	3,324 lb.	UNA-040, WG-4

SLIPPER FLAT - 2" WIDE

PART #	# OF LEAVES	FREE LENGTH	FREE ARCH	CAP. PER SPRING	BUSHING ID.	WEIGHT EA.	SKID QTY.	SKID WT.
SF-7210RB	6	30.00"	3.87"	4,500 lb.	9/16"	31.52 lb.	100 pc.	3,152 lb.

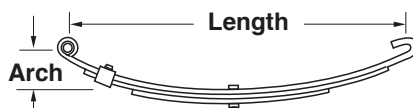

SLIPPER OPEN - 1-3/4" WIDE

PART #	# OF LEAVES	FREE LENGTH	FREE ARCH	CAP. PER SPRING	BUSHING ID.	WEIGHT EACH	SKID QTY.	SKID WEIGHT	REFERENCE #S
SO-C1	2	26.25"	3.50"	800 lb.	9/16"	8.30 lb.	250 pc.	2,075 lb.	UNA-261, C1
SO-C2	3	26.25"	3.50"	1,300 lb.	9/16"	10.70 lb.	200 pc.	2,140 lb.	UNA-262, C-2
SO-C3	3	26.25"	3.50"	1,750 lb.	9/16"	12.10 lb.	200 pc.	2,428 lb.	UNA-263, C-3
SO-C4	4	26.25"	3.50"	2,350 lb.	9/16"	14.90 lb.	200 pc.	2,974 lb.	UNA-264, C-4
SO-C5	5	26.25"	3.50"	2,850 lb.	9/16"	17.40 lb.	150 pc.	2,613 lb.	UNA-265, C-5
SO-C6	6	26.25"	3.50"	3,500 lb.	9/16"	21.30 lb.	125 pc.	2,661 lb.	UNA-211, C-6
SO-C21.03	3	26.25"	3.50"	1,300 lb.	No Bushing	10.70 lb.	200 pc.	2,140 lb.	C-2 Large Eye
SO-C31.03	3	26.25"	3.50"	1,750 lb.	No Bushing	12.10 lb.	200 pc.	2,428 lb.	C-3 Large Eye
SO-C41.03	4	26.25"	3.50"	2,350 lb.	No Bushing	14.90 lb.	200 pc.	2,974 lb.	C-4 Large Eye
SO-C51.03	5	26.25"	3.50"	2,850 lb.	No Bushing	17.40 lb.	150 pc.	2,613 lb.	C-5 Large Eye
SO-C61.03	6	26.25"	3.50"	3,500 lb.	No Bushing	21.30 lb.	125 pc.	2,661 lb.	C-6 Large Eye

**Replacement in pairs is recommended for proper axle alignment and suspension performance.

- For non-stock items minimum order quantities and longer lead time will apply.

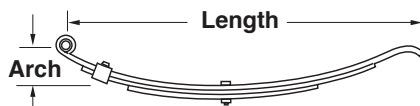

SLIPPER RADIUS - 1-3/4" WIDE

PART #	# OF LEAVES	FREE LENGTH	FREE ARCH	CAP. PER SPRING	BUSHING ID.	WEIGHT EACH	SKID QUANTITY	SKID WEIGHT	REF. #S
SR-WH4	4	24.62"	4.50"	1,000 lb.	9/16"	9.00 lb.	200 pc.	1,800 lb.	UNA-179, WH-4
SR-WI5	5	24.62"	4.50"	1,200 lb.	9/16"	12.10 lb.	200 pc.	2,420 lb.	UNA-180, WI-5
SR-WC2	2	24.62"	4.50"	550 lb.	9/16"	5.40 lb.	250 pc.	1,350 lb.	UNA-177, WC-2
SR-WE3	3	24.62"	4.50"	750 lb.	9/16"	7.80 lb.	200 pc.	1,558 lb.	UNA-178, WE-3
SR-722	2	27.00"	4.19"	1,000 lb.	9/16"	10.28 lb.	300 pc.	3,150 lb.	
SR-024	4	32.00"	4.25"	1,100 lb.	9/16"	12.40 lb.	200 pc.	2,480 lb.	UNA-024, 23724
SR-028	2	32.00"	4.25"	600 lb.	9/16"	7.80 lb.	200 pc.	1,558 lb.	UNA-028
SR-034	3	32.00"	4.25"	800 lb.	9/16"	10.90 lb.	200 pc.	2,180 lb.	UNA-034

SLIPPER RADIUS- 2-1/2" WIDE

SR-7280	5	30.50"	4.00"	5,000 lb.	9/16"	31.91 lb.	95 pc.	3,085 lb.	72-80
---------	---	--------	-------	-----------	-------	-----------	--------	-----------	-------

SLIPPER RADIUS - 3" WIDE

SR-7243	5	30.50"	3.94"	5,000 lb.	9/16"	40.26 lb.	50 pc.	2,063 lb.	72-43
SR-7244	6	30.50"	3.94"	6,000 lb.	1.00"	44.22 lb.	65 pc.	2,910 lb.	72-44
SR-7245	7	30.50"	4.00"	7,500 lb.	9/16"	50.84 lb.	50 pc.	2,595 lb.	72-45

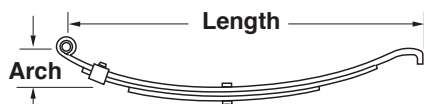

SLIPPER HOOK- 2" WIDE

PART #	# OF LEAVES	FREE LENGTH	FREE ARCH	CAPACITY PER SPRING	BUSHING ID.	WEIGHT EACH	SKID QUANTITY	SKID WEIGHT	REF. #S
SH-7229	4	26.50"	3.18"	1,500 lb.	9/16"	15.80 lb.	150 pc.	2,366 lb.	UNA-229, 60-3T3
SH-7230	4	26.50"	3.00"	2,000 lb.	9/16"	16.40 lb.	150 pc.	2,460 lb.	UNA-230, 80-3T3
SH-7231	4	26.50"	3.06"	2,500 lb.	9/16"	17.60 lb.	150 pc.	2,640 lb.	UNA-231, 100-3T3
SH-E5226	5	26.50"	3.50"	3,400 lb.	9/16"	20.50 lb.	125 pc.	2,563 lb.	UNA-160, 5226
SH-7232	5	26.50"	3.18"	3,500 lb.	9/16"	20.40 lb.	125 pc.	2,550 lb.	UNA-232, 120-3T3
SH-7232RB	5	26.50"	3.18"	3,500 lb.	9/16"	20.50 lb.	125 pc.	2,563 lb.	120-3T3 RB
SH-HW5116	6	26.50"	3.50"	3750 lb.	9/16"	23.30 lb.	140 pc.	3,315 lb.	HW5116
SH-7233-RB2	7	26.50"	3.00"	4,000 lb.	9/16"	27.00 lb.	125 pc.	3,375 lb.	UNA-233, 140-3T3
SH-E5115	6	29.50"	3.50"	4,300 lb.	9/16"	24.72 lb.	120/156 pc.	3,016 lb.	E5115



3-LEAF TAPER HEAVY-DUTY SPRINGS

PART #	# OF LEAVES	FREE LENGTH	FREE ARCH	CAPACITY PER SPRING	BUSHING ID.	WEIGHT EACH	SKID QUANTITY	SKID WEIGHT
TRA-2752	2	43.48"	6.69"	11,200 lb.	N/A	52.10 lb.	65 pc.	3,437 lb.
TRA-2754	2	43.73"	4.09"	11,200 lb.	N/A	51.60 lb.	65 pc.	3,404 lb.
TRA-2740	3	43.73"	5.75"	12,000 lb.	N/A	65.50 lb.	50 pc.	3,325 lb.
TRA-2726	3	43.74"	6.25"	11,200 lb.	N/A	54.50 lb.	65 pc.	3,593 lb.
TRA-2727	3	43.80"	4.88"	11,200 lb.	N/A	53.30 lb.	65 pc.	3,515 lb.
TRA-2741	3	43.80"	3.38"	12,000 lb.	N/A	64.20 lb.	50 pc.	3,260 lb.
TRA-2728	3	43.81"	3.81"	11,200 lb.	N/A	52.90 lb.	65 pc.	3,489 lb.
TRA-2726HD	4	44.25"	5.43"	14,000 lb.	N/A	71.60 lb.	50 pc.	3630 lb.

LEAF SPRINGS & BUSHINGS

Leaf Spring & Equalizer Bushings

GRAPHITE IMPREGNATED
NYLON AND RUBBER/STEEL

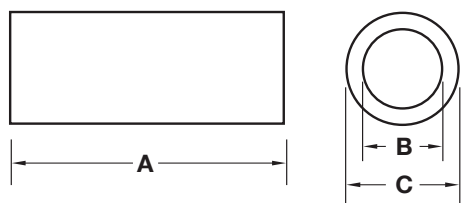

BU1-B1.38X2.19



BU1-B2.06X.7X2.5RB



BUI-1561



BUI-1508



BUI-1566



BUI-1506

PART #	PACKAGED PARTS KIT#	DIMENSIONS			REF. #	BOX QUANTITY	BOX WEIGHT
		A (LENGTH)	B (ID.)	C (OD.)			
BU1-1506		1.75"	0.5000"	0.6875"	226	300 pc.	6 lb.
BU1-1508		1.75"	0.5000"	0.8750"	224, W-5	300 pc.	6 lb.
BU1-1566	PP-BUK-1	1.75"	0.5625"	0.6875"	227, W-1	300 pc.	6 lb.
BU1-1566B		1.75"	0.5625"	0.6875"	Bronze	300 pc.	25 lb.
BU1-1568		1.75"	0.5625"	0.8750"	225, W-3	300 pc.	6 lb.
BU1-1561		1.75"	0.5625"	1.0400"	228	300 pc.	7 lb.
BU1-2566	PP-BUK-2	2.00"	0.5625"	0.6875"	229, W-2	300 pc.	8 lb.
BU1-3871		3.00"	0.8800"	1.1250"	NB 78	150 pc.	7 lb.
BU1-1750		1.75"	0.7500"	0.8750"	NB for EQ-E34 Center Bushing	300 pc.	6 lb.
BU1-1758		1.75"	0.7500"	0.8750"		300 pc.	6 lb.
BU1-2881		2.00"	0.8800"	1.0800"	NB for EQ-5541,4541 Center Bushing	500 pc.	8 lb.
BU1-B1.38X2.19		2.19"	0.5620"	1.3800"	Rubber/Steel	150 pc.	25 lb.
BU1-B2.06X.7X2.5RB		2.50"	0.7500"	2.0000"	Rubber/Steel	150 pc.	25 lb.

• See Packaged Parts on pg 75

*Above quantities are approximate, actual shipment may vary.

LEAF SPRINGS & BUSHINGS

U-Bolt Tie Plates

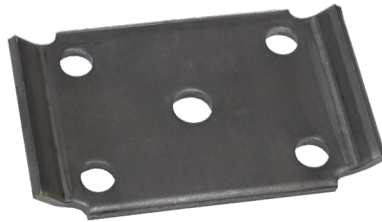
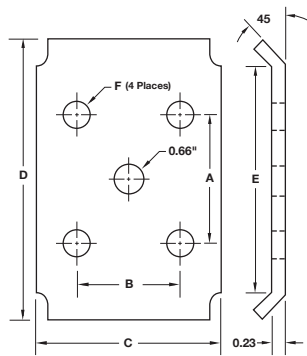

TP-300175 Shown / Type 1

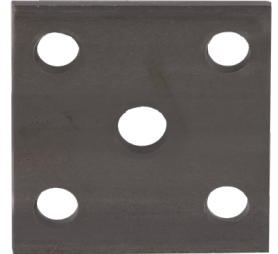
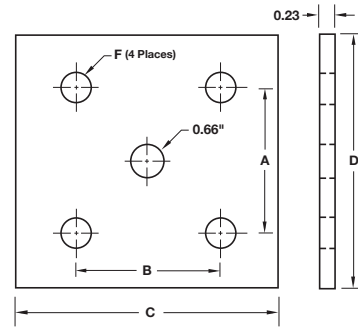

TP-175175 Shown / Type 2

PART #	TYPE	TUBE DIA.	SPRING WIDTH	DIMENSIONS						REF #	CASE QTY.	CASE WT.
				A	B	C	D	E	F			
TP-175173	2	1.75"	1.75"	2.19"	2.19"	3.75"	3.50"	N/A	0.41"	TP-7	1,000 pc.	880 lb.
TP-175175	2	1.75"	1.75"	2.31"	2.31"	3.75"	3.50"	N/A	0.56"	12-14	1,000 pc.	840 lb.
TP-200175	1	2.00"	1.75"	2.63"	2.38"	4.00"	5.92"	4.80"	0.62"	—	1,000 pc.	1,370 lb.
TP-200175-T2	2	2.00"	1.75"	2.63"	2.38"	3.50"	3.50"	N/A	0.56"	—	1,000 pc.	776 lb.
TP-200175-56	1	2.00"	1.75"	2.63"	2.38"	3.50"	5.92"	4.80"	0.56"	—	1,000 pc.	1,320 lb.
TP-238175	1	2.38"	1.75"	2.94"	2.31"	3.75"	5.92"	4.80"	0.56"	12-3	2,000 pc.	2,690 lb.
TP-238200	1	2.38"	2.00"	2.94"	2.56"	4.00"	5.92"	4.80"	0.56"	12-4	2,000 pc.	1,560 lb.
TP-300175	1	3.00"	1.75"	3.62"	2.38"	3.75"	5.92"	4.80"	0.56"	12-1	2,000 pc.	2,690 lb.
TP-300200	1	3.00"	2.00"	3.56"	2.59"	4.00"	5.92"	4.80"	0.56"	12-2	2,000 pc.	2,560 lb.
TP-300209	1	3.00"	2.00"	3.56"	2.59"	4.00"	5.92"	4.80"	0.62"	21-12-2	2,000 pc.	2,850 lb.
TP-350200	1	3.50"	2.00"	4.13"	2.63"	4.00"	7.00"	5.69"	0.69"	—	350 pc.	750 lb.

ADDITIONAL SPECS

- Material: High quality pickled and oiled structural steel per ASTM specifications
- Available galvanized and with clear or yellow chromate on zinc, call for pricing and availability
- See Packaged Parts on pg 74

*For Non-stock items, minimum order quantities will apply.

U-Bolt Tie Plates

RIBBED

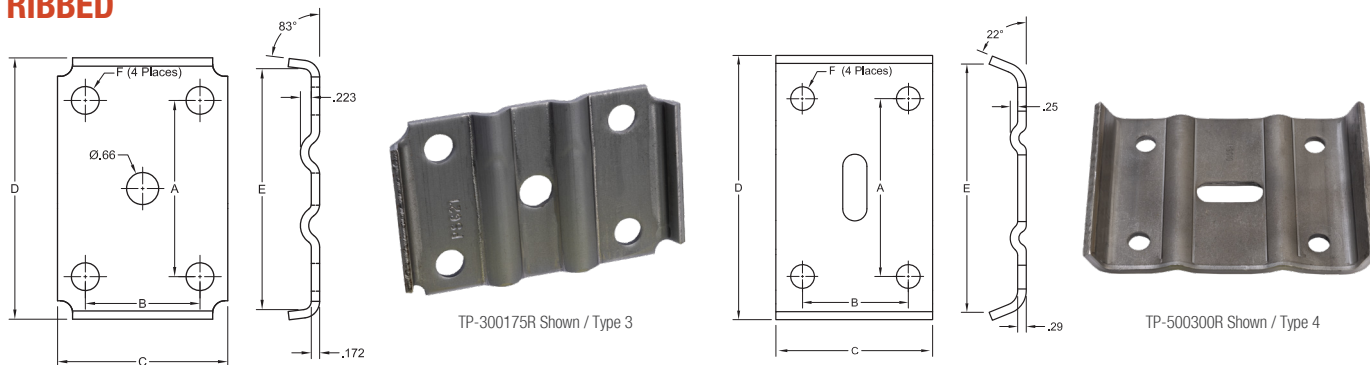

PART #	TYPE	TUBE DIA.	SPRING WIDTH	DIMENSIONS						REF #	CASE QTY.	CASE WT.
				A	B	C	D	E	F			
TP-238175-50R	3	2.38"	1.75"	2.88"	2.25"	3.50"	4.75"	4.58"	0.50"	—	2,000 pc.	2,200 lb.
TP-238175R	3	2.38"	1.75"	2.94"	2.31"	3.75"	4.75"	4.58"	0.56"	—	2,000 pc.	2,250 lb.
TP-238200R	3	2.38"	2.00"	2.88"	2.50"	3.75"	4.75"	4.58"	0.50"	—	1,000 pc.	1,150 lb.
TP-300175R	3	3.00"	1.75"	3.62"	2.35"	3.50"	5.37"	5.20"	0.56"	—	2,000 pc.	2,250 lb.
TP-300200-56R	3	3.00"	2.00"	3.62"	2.60"	3.75"	5.37"	5.20"	0.56"	—	2,000 pc.	2,890 lb.
TP-300209R	3	3.00"	2.00"	3.56"	2.59"	4.00"	5.92"	5.20"	0.62"	21-12-2	2,000 pc.	2,400 lb.
TP-500250R	4	5.00"	2.50"	5.77"	3.25"	5.00"	9.00"	8.24"	0.69"	12-49	250 pc.	1,000 lb.
TP-500300R	4	5.00"	3.00"	5.75"	3.88"	6.00"	9.00"	8.24"	0.69"	12-53	200 pc.	1,180 lb.
TP-500300-81R	4	5.00"	3.00"	5.87"	3.88"	6.00"	9.00"	8.24"	0.81"	12-46	200 pc.	1,100 lb.
TP-513250R	4	5.13"	2.50"	5.94"	3.38"	5.00"	9.00"	8.24"	0.81"	—	250 pc.	1,000 lb.

ADDITIONAL SPECS

- Material: High quality, HSLA pickled and oiled structural steel per ASTM specifications
- Available galvanized and with clear or yellow chromate on zinc, call for pricing and availability
- See Packaged Parts on pg 74

*For Non-stock items, minimum order quantities will apply.

U-Bolts

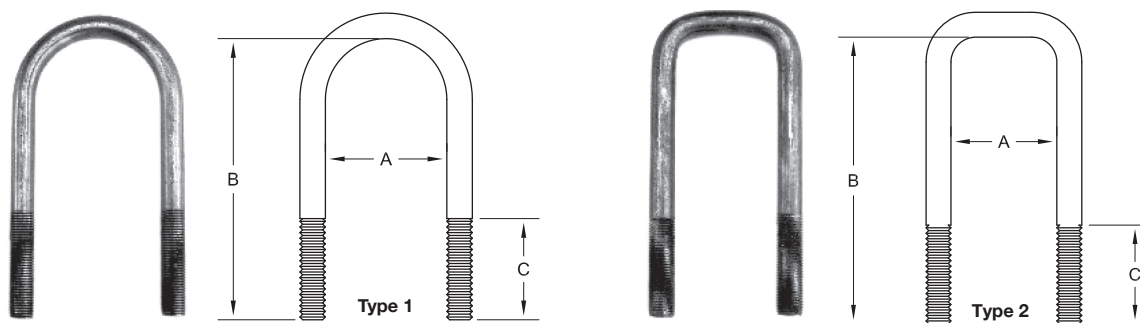

PART #	PACKAGED PARTS KIT#	TYPE	TUBE DIA.	SPRING WIDTH	THREAD SIZE	DIMENSIONS			UNIT WT.	CASE QTY.	CASE WT.
						A	B	C			
UBR-175429-38C	PP-UBK-1	1	1.75"	1.75"	3/8" - 16"	1.81"	4.29"	2.00"	0.24 lb.	4,000 pc.	1,100 lb.
UBR-175429-38F		1	1.75"	1.75"	3/8" - 24"	1.81"	4.29"	2.00"	0.24 lb.	4,000 pc.	1100 lb.
UBR-175429-50F		1	1.75"	1.75"	1/2" - 20"	1.81"	4.29"	2.00"	0.49 lb.	2,000 pc.	1000 lb.
UBR-238513-44F		1	2.38"	1.75 - 2.00"	7/8" - 20"	2.44"	5.13"	2.00"	0.46 lb.	7,000 pc.	3,300 lb.
UBR-238550-50F	PP-UBK-2	1	2.38"	1.75 - 2.00"	1/2" - 20"	2.44"	5.50"	2.00"	0.62 lb.	5,000 pc.	3,150 lb.
UBR-238625-50F	PP-UBK-3	1	2.38"	1.75 - 2.00"	1/2" - 20"	2.44"	6.25"	3.00"	0.70 lb.	1,000 pc.	750 lb.
UBR-300650-50F	PP-UBK-4	1	3.00"	1.75 - 2.00"	1/2" - 20"	3.09"	6.50"	2.00"	0.74 lb.	4,000 pc.	3,000 lb.
UBR-300700-50F	PP-UBK-5	1	3.00"	1.75 - 2.00"	1/2" - 20"	3.09"	7.00"	2.00"	0.78 lb.	3,500 pc.	2,900 lb.
UBR-300700-56F		1	3.00"	1.75 - 2.00"	9/16" - 18"	3.09"	7.00"	3.00"	1.02 lb.	2,500 pc.	2,750 lb.
UBR-350800-56F		1	3.50"	2.00"	9/16" - 18"	3.56"	8.00"	2.00"	1.16 lb.	300 pc.	500 lb.
UBR-500900-63C		1	5.00"	2.50 - 3.00"	5/8" - 11"	5.06"	9.00"	2.00"	1.89 lb.	1,500 pc.	3,900 lb.
UBS-200575-56F		2	2.00"	1.75"	9/16" - 18"	2.06"	5.75"	2.50"	0.82 lb.	1,000 pc.	950 lb.
UBS-200650-56F		2	2.00"	1.75"	9/16" - 18"	2.09"	6.50"	2.50"	0.95 lb.	3,200 pc.	3,100 lb.

ADDITIONAL SPECS

- Material: SAE 1018 Hot Rolled
- Stainless steel available, call for lead time and pricing
- Available with clear or yellow chromate on zinc plating and galvanized, call for lead time and pricing
- Letter at the end of the part number denoted course (C) or fine (F) thread
- See U-Bolt/Tie Plate Packaged Parts on pg 74

Spring Seats

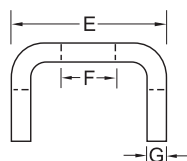
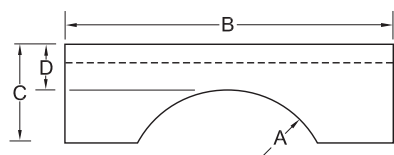

Round Tube / Type 1

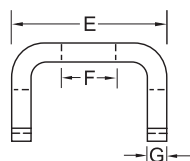
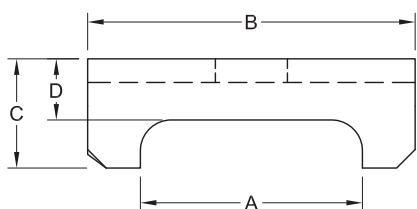

Square/Rectangular Tube / Type 2

PART #	TYPE	TUBE DIA.	DIMENSIONS							REF #	UNIT WT.	CASE QTY.	CASE WT.
			A	B	C	D	E	F	G				
SS-175	1	1.75"	0.88"	2.25"	0.94"	0.53"	1.85"	0.67"	0.22"	3-23	0.38 lb.	2,000 pc.	745 lb.
SS-238	1	2.38"	1.19"	4.00"	1.20"	0.56"	1.85"	0.67"	0.22"	3-8	0.77 lb.	3,000 pc.	1,600 lb.
SS-300	1	3.00"	1.51"	4.00"	1.20"	0.56"	1.85"	0.67"	0.22"	3-1	0.74 lb.	1,000 pc.	770 lb.
SS-350	1	3.50"	1.76"	4.00"	1.20"	0.56"	1.85"	0.67"	0.22"	90316	0.75 lb.	1,000 pc.	400 lb.
SS-500	1	5.00"	2.54"	6.00"	1.60"	0.78"	2.50"	0.88"	0.38"	N/A	2.14 lb.	500 pc.	1,100 lb.
SS-200	2	2.00"	2.03"	3.00"	0.94"	0.53"	1.85"	0.67"	0.22"	N/A	0.45 lb.	2,000 pc.	920 lb.

ADDITIONAL SPECS

- Material: High quality, pickled and oiled structural steel per ASTM specifications
- Available galvanized and with clear or yellow chromate on zinc, call for pricing and availability

*For Non-stock items, minimum order quantities will apply.

Shackle Links

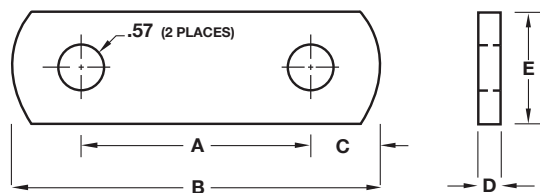

PART #	PACKAGED PARTS KIT#	DIMENSIONS					REF #	UNIT WT.	CASE QTY.	CASE WT.
		A	B	C	D	E				
SL-200	N/A	2.00"	3.25"	0.63"	0.22"	1.25"	18-11	0.230 lb.	2,000 pc.	490 lb.
SL-225	PP-SLK-1	2.25"	3.50"	0.63"	0.22"	1.25"	115841D	0.235 lb.	6,000 pc.	1,460 lb.
SL-250	N/A	2.50"	3.78"	0.63"	0.22"	1.25"	—	0.240 lb.	2,000 pc.	510 lb.
SL-256	PP-SLK-2	2.56"	3.81"	0.63"	0.22"	1.25"	18-115	0.240 lb.	2,000 pc.	510 lb.
SL-263	N/A	2.63"	3.90"	0.63"	0.22"	1.25"	—	0.261 lb.	2,000 pc.	552 lb.
SL-275	N/A	2.75"	4.00"	0.63"	0.22"	1.25"	N/A	0.264 lb.	2,000 pc.	558 lb.
SL-313	PP-SLK-3	3.13"	4.38"	0.63"	0.22"	1.25"	18-12	0.285 lb.	2,000 pc.	600 lb.
SL-350	N/A	3.50"	4.75"	0.63"	0.22"	1.25"	18-3.5	0.314 lb.	6,000 pc.	1,974 lb.
SL-363	N/A	3.63"	4.90"	0.63"	0.22"	1.25"	—	0.263 lb.	2,000 pc.	556 lb.
SL-425	N/A	4.25"	5.53"	0.63"	0.22"	1.25"	—	0.335 lb.	2,000 pc.	700 lb.
SL-475	N/A	4.75"	6.03"	0.63"	0.25"	1.25"	—	0.405 lb.	2,000 pc.	840 lb.
SL-225-150	N/A	2.25"	3.53"	0.63"	0.25"	1.50"	—	0.420 lb.	2,000 pc.	870 lb.
SL-250-150	N/A	2.50"	3.78"	0.63"	0.25"	1.50"	—	0.440 lb.	2,000 pc.	910 lb.
SL-275-150	N/A	2.75"	4.03"	0.63"	0.22"	1.50"	—	0.470 lb.	2,000 pc.	970 lb.
SL-313-150	N/A	3.13"	4.40"	0.63"	0.25"	1.50"	—	0.340 lb.	2,000 pc.	710 lb.
SL-375-150	N/A	3.75"	5.03"	0.63"	0.22"	1.50"	—	0.580 lb.	2,000 pc.	1,190 lb.
SL-400-150	N/A	4.00"	5.28"	0.63"	0.22"	1.50"	—	0.445 lb.	2,000 pc.	920 lb.
SL-450-150	N/A	4.50"	5.78"	0.63"	0.25"	1.50"	—	0.470 lb.	2,000 pc.	500 lb.
SL-525-150	N/A	5.25"	6.53"	0.63"	0.25"	1.50"	—	0.740 lb.	2,000 pc.	1,510 lb.
SL-556-150	N/A	5.56"	6.84"	0.63"	0.25"	1.50"	—	0.780 lb.	2,000 pc.	1,590 lb.

ADDITIONAL SPECS

- Material: High quality, pickled and oiled structural steel per ASTM specifications
- Shackle links available with clear or yellow chromate on zinc plate and galvanized, call for pricing and availability
- See Packaged Parts on pg 74

*For Non-stock items, minimum order quantities will apply.

SHACKLE BOLTS

All Shackle Links are available with shackle bolts pressed in. Add "B" to the end of the part #.



Shock Absorber

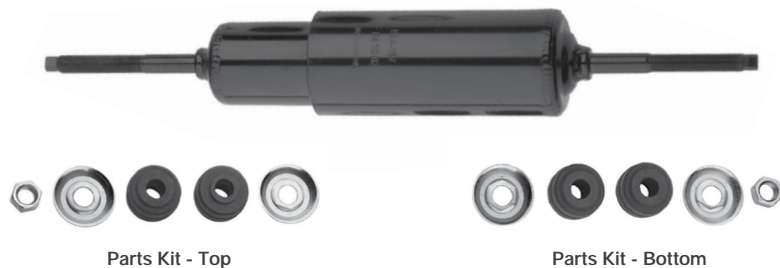

PART #	DESCRIPTION	UNIT WT.	CASE QTY.	CASE WT.
SA-568167	RV Shock w/ Parts Kit	2.75 lb.	722 pc.	1,986 lb.

Shock Tie Plates

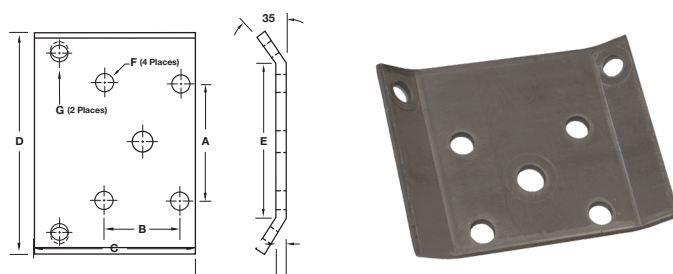

PART #	TUBE DIA.	SPRING WIDTH	DIMENSIONS							CASE QTY.	CASE WT.
			A	B	C	D	E	F	G		
TP-7710	2.38"	1.75"	2.94"	2.31"	5.00"	5.92"	4.69"	0.56"	0.53"	1,500 pc.	3,128 lb.
TP-7709	3.00"	2.00"	3.62"	2.38"	5.00"	5.92"	4.69"	0.56"	0.53"	1,500 pc.	3,128 lb.

- Material: High quality pickled and oiled structural steel per ASTM specifications

*For Non-stock items, minimum order quantities will apply.

Shock Mounting Bracket

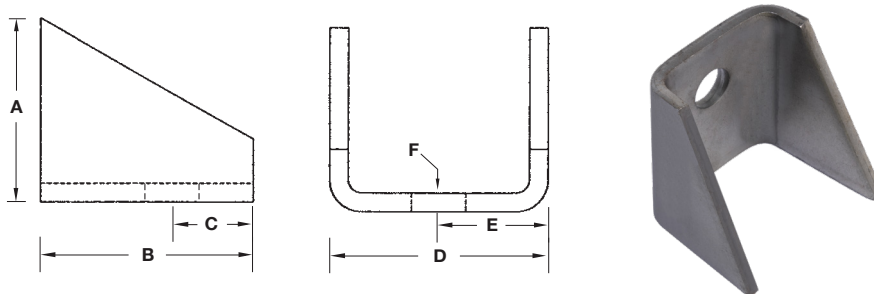

PART #	DIMENSIONS						CASE QTY.	CASE WT.
	A	B	C	D	E	F		
ST-BRKT-205	1.75"	2.00"	0.69"	2.05"	1.02"	0.50"	1,000 pc.	400 lb.
ST-BRKT-325	2.75"	3.25"	0.69"	2.05"	1.02"	0.50"	1,000 pc.	760 lb.

Spring Hangers

1-3/4" WIDE SPRINGS



HG-SS / Type 3

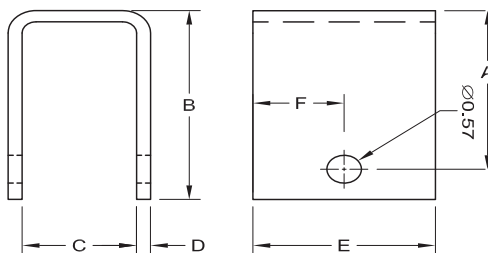
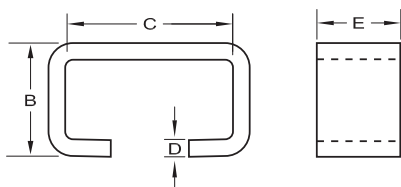

HG-325 / Type 1

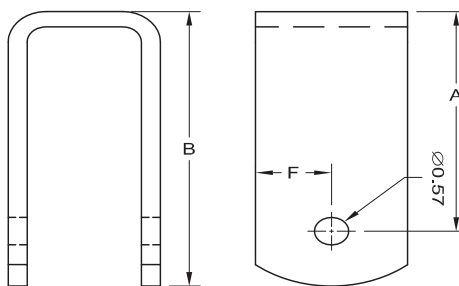

HG-350 / Type 2

PART #	TYPE	DIMENSIONS						REF. #	UNIT WT.	CASE QTY.	CASE WT.
		A	B	C	D	E	F				
HG-100	1	1.13"	2.13"	1.44"	0.23"	1.50"	0.75"	—	0.41 lb.	1,000 pc.	407 lb.
HG-112	1	1.12"	2.13"	1.30"	0.23"	3.00"	1.50"	93003X	1.20 lb.	2,000 pc.	2,400 lb.
HG-144	1	1.44"	2.06"	1.88"	0.23"	3.00"	1.50"	28-6	0.67 lb.	2,000 pc.	1,340 lb.
HG-200	1	2.00"	2.63"	1.88"	0.23"	3.00"	1.50"	29-8	1.21 lb.	1,000 pc.	1,205 lb.
HG-246	1	2.46"	3.09"	1.88"	0.23"	3.00"	1.50"	28-3	1.37 lb.	750 pc.	1,027 lb.
HG-325	1	3.25"	3.87"	1.88"	0.23"	3.00"	1.50"	28-5	1.66 lb.	1,500 pc.	2,490 lb.
HG-425	1	4.25"	4.87"	1.88"	0.23"	3.00"	1.50"	28-4	2.18 lb.	500 pc.	1,080 lb.
HG-538	1	5.38"	6.19"	1.88"	0.38"	3.00"	1.50"	—	4.53 lb.	500 pc.	2,265 lb.
HG-194	2	1.94"	2.81"	1.88"	0.22"	2.50"	1.25"	—	0.77 lb.	1,000 pc.	770 lb.
HG-350	2	3.50"	4.38"	1.88"	0.22"	2.50"	1.25"	—	1.39 lb.	750 pc.	1,040 lb.
HG-475	2	4.75"	5.63"	1.88"	0.30"	2.50"	1.25"	—	2.52 lb.	500 pc.	1,260 lb.
HG-SS	3	N/A	1.21"	2.00"	0.21"	1.00"	N/A	4104-4	0.28 lb.	500 pc.	561 lb.

ADDITIONAL SPECS

- Material: High quality, pickled and oiled structural steel per ASTM specifications
- Other spring hardware available upon request
- See HANGER KIT Packaged Parts on pg 78

*Non-stock items. Minimum order quantities will apply.

Spring Hangers

2" WIDE SPRINGS

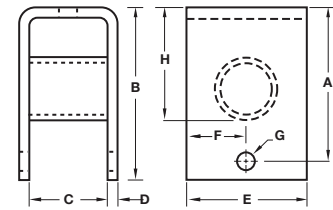
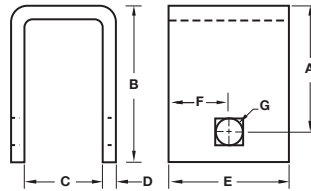
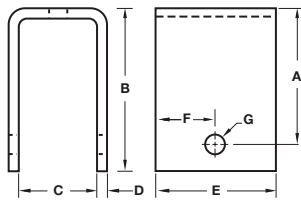
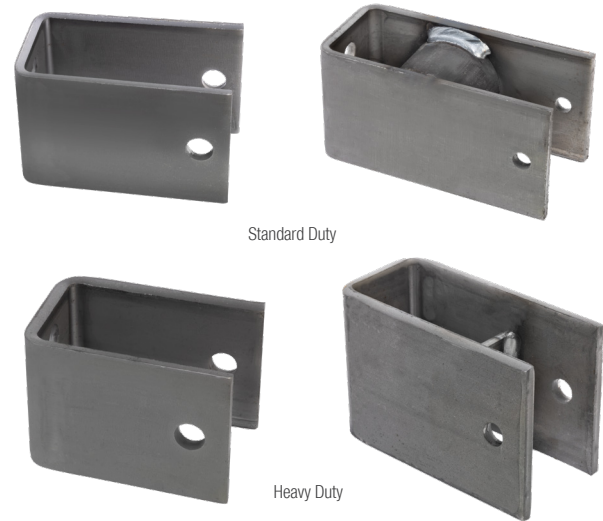

PART #	DIMENSIONS								REF. #	UNIT WT.	CASE QTY.	CASE WT.
	A	B	C	D	E	F	G	H				
HG-281-F	4.25"	4.88"	2.25"	0.25"	3.00"	1.50"	0.57"	N/A	28-1	2.43 lb.	400 pc.	970 lb.
HG-291-C	3.50"	4.50"	3.06"	0.31"	3.00"	1.50"	0.89/0.90"	N/A	29-1	2.80 lb.	375 pc.	1,050 lb.
HG-3028-R	5.37"	6.00"	2.25"	0.25"	3.00"	1.50"	0.38"	3.75"	30-28	3.32 lb.	250 pc.	830 lb.
HG-2891-F	5.00"	5.63"	2.25"	0.25"	3.00"	1.50"	0.57"	2.88"	28-9-1	3.28 lb.	250 pc.	820 lb.
HG-2951-C	4.50"	5.53"	3.06"	0.31"	3.00"	1.50"	0.89/0.90"	2.48"	29-5-1	4.08 lb.	250 pc.	1,020 lb.
HG-3061-R	6.43"	7.06"	2.25"	0.25"	3.00"	1.50"	0.38"	4.82"	30-6-1	3.76 lb.	350 pc.	940 lb.
HG-15844-F	3.56"	4.31"	2.19"	0.30"	4.00"	2.00"	0.57"	N/A	1584-4	3.32 lb.	500 pc.	1,663 lb.
HG-15864-C	3.38"	4.50"	3.13"	0.30"	4.00"	2.00"	0.84/0.90"	N/A	1586-4	3.69 lb.	500 pc.	1,847 lb.
HG-15854-R	5.06"	6.00"	2.19"	0.30"	4.00"	2.00"	0.57"	3.47"	1585-4	4.78 lb.	500 pc.	2,391 lb.
HG-15843-F	3.56"	4.31"	2.19"	0.30"	3.00"	1.50"	0.57"	N/A	1584	2.52 lb.	750 pc.	1,888 lb.
HG-15863-C	3.38"	4.50"	3.13"	0.37"	3.00"	1.50"	0.84/0.90"	N/A	1586	3.31 lb.	750 pc.	2,480 lb.
HG-15853-R	5.06"	6.00"	2.19"	0.30"	3.00"	1.50"	0.57"	3.47"	1585	3.34 lb.	750 pc.	2,500 lb.

ADDITIONAL SPECS

- Material: High quality, hot-rolled structural steel per ASTM specifications
- Other spring hardware available upon request
- See HANGER KIT Packaged Parts on pg 78

*Non-stock items. Minimum order quantities will apply.

Steel Fabricated Equalizers

2" WIDE SPRINGS

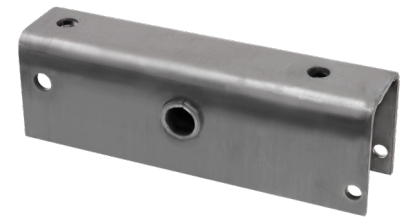
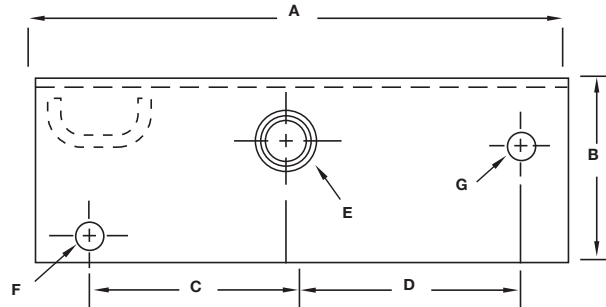

PART #	DIMENSIONS								REF. #	UNIT WT.	CASE QTY.	CASE WT.
	A	B	C	D	E	F	G	t				
EQ-1304	11.00"	3.50"	5.19"	4.63"	0.88"	0.44"	0.56"	0.22"	13-4	6.60 lb.	144 pc.	950 lb.
EQ-5541	12.00"	4.00"	4.44"	4.75"	0.88"	0.56"	0.56"	0.31"	5541	9.80 lb.	126 pc.	1,235 lb.
EQ-4541	12.00"	4.00"	4.44"	4.75"	0.88"	0.56"	0.56"	0.24"	4541	8.20 lb.	126 pc.	1,035 lb.
EQ-1344	13.00"	3.50"	5.94"	5.50"	0.88"	0.44"	0.56"	0.22"	13-44-1	7.78 lb.	144 pc.	1,120 lb.

NOTE: Center bushing for EQ-5541 and EQ-4541 utilize .88" ID. nylon bushing encased in a 1.31" OD. x 1.06" ID. steel tube.

ADDITIONAL SPECS

- Material: High quality hot-rolled structural steel
- All equalizers use a 0.88" equalizer bolt
- Dimension "t" equals thickness of material
- EQ-1304 and EQ-1344 not supplied with nylon bushing

Cast Equalizers

All cast equalizers are manufactured from ductile iron. Equalizers are manufactured to industry standards and come finished in black paint.

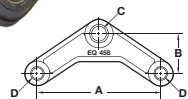

EQ-458

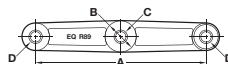

EQ-R89

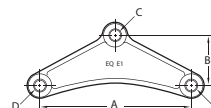

EQ-E1

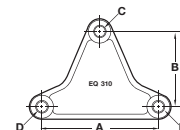

EQ-310

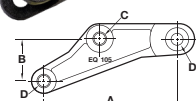

EQ-105

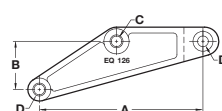

EQ-126

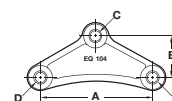

EQ-104

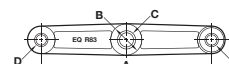

EQ-R83

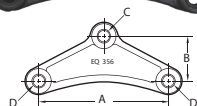

EQ-356

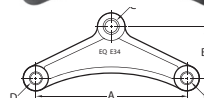

EQ-E34

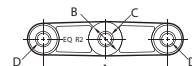

EQ-R2

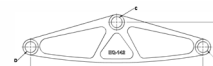

EQ-142

PART #	DIMENSIONS				UNIT WT.	CASE QTY.	CASE WT.
	A	B	C	D			
EQ-R2	5.50"	1.50"	0.563"	0.563"	2.65 lb.	250 pc.	742 lb.
EQ-104	5.75"	2.00"	0.563"	0.563"	1.95 lb.	1,000 pc.	2,000 lb.
EQ-310	6.06"	4.00"	0.563"	0.563"	2.85 lb.	630 pc.	1,835 lb.
EQ-310Z - Galvanized	6.06"	4.00"	0.563"	0.563"	2.85 lb.	840 pc.	2,442 lb.
EQ-356	6.13"	2.50"	0.563"	0.563"	2.25 lb.	1,000 pc.	2,320 lb.
EQ-356Z - Galvanized	6.13"	2.50"	0.563"	0.563"	2.25 lb.	1,000 pc.	2,320 lb.
EQ-458	6.25"	2.00"	0.750"	0.563"	2.36 lb.	900 pc.	2,164 lb.
EQ-105	6.75"	2.00"	0.563"	0.563"	3.45 lb.	576 pc.	2,028 lb.
EQ-E1	7.75"	2.88"	0.563"	0.563"	2.75 lb.	700 pc.	1,965 lb.
EQ-E1Z - Galvanized	7.75"	2.88"	0.563"	0.563"	2.75 lb.	700 pc.	1,965 lb.
EQ-E34	7.75"	2.88"	0.750"	0.563"	3.45 lb.	700 pc.	2,455 lb.
EQ-R83	8.00"	1.75"	0.750"	0.563"	3.30 lb.	200 pc.	700 lb.
EQ-R89	8.00"	1.75"	0.563"	0.563"	3.35 lb.	200 pc.	710 lb.
EQ-126	9.06"	3.00"	0.563"	0.563"	3.90 lb.	300 pc.	1,210 lb.
EQ-142	14.75"	1.75"	0.563"	0.563"	9.29 lb.	250 pc.	2,362 lb.

* See pg 78 for Tandem Axle Hanger Kit

10K General Duty Steel Fabricated Equalizers

2-1/2" WIDE SPRINGS

The following steel fabricated equalizers are designed for the use of 2-1/2" wide slipper springs in a tandem or triple axle application.

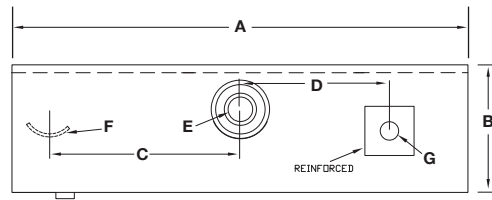
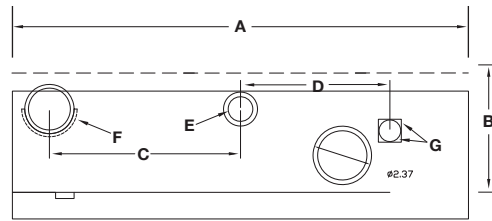
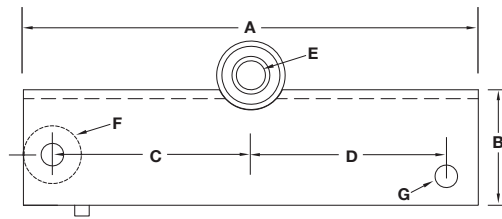

EQ-5000GD, EQ-6000GD



EQ-42LH, EQ-42RH, EQ-48LH, EQ-48RH



EQ-13140, EQ-13141

PART #	DIMENSIONS								REF #	UNIT WT.	CASE QTY.	CASE WT.
	A	B	C	D	E	F	G	t				
EQ-5000GD	15.75"	4.75"	7.00"	7.88"	1.00"	2.38"	0.78"	0.31"	5000GD	20 lb.	201 pc.	2,600 lb.
EQ-6000GD	21.75"	4.75"	10.00"	10.88"	1.00"	2.38"	0.78"	0.31"	6000GD	26 lb.	154 pc.	2,600 lb.
EQ-42LH	18.50"	5.19"	7.75"	7.06"	1.00"	2.16"	0.77"	0.25"	13-082	18 lb.	126 pc.	2,282 lb.
EQ-42RH	18.50"	5.19"	7.75"	7.06"	1.00"	2.16"	0.77"	0.25"	13-083	18 lb.	126 pc.	2,282 lb.
EQ-48LH	24.63"	5.19"	10.88"	10.25"	1.00"	2.16"	0.77"	0.25"	13-084	24 lb.	102 pc.	2,467 lb.
EQ-48RH	24.63"	5.19"	10.88"	10.25"	1.00"	2.16"	0.77"	0.25"	13-085	24 lb.	102 pc.	2,467 lb.
EQ-13140	18.38"	5.19"	7.13"	6.75"	1.00"	2.25"	0.75"	0.20"	13-140	15 lb.	135 pc.	2,025 lb.
EQ-13141	24.75"	5.19"	10.38"	10.00"	1.00"	2.25"	0.75"	0.20"	13-141	20 lb.	100 pc.	2,000 lb.

ADDITIONAL SPECS

- Made to industry standards and supplied as oiled metal
 - Material: High quality hot-rolled structural steel
 - All equalizers use a 1" equalizer bolt
 - Dimension "t" = thickness of material
- * See pg 78 for Tandem Axle Hanger Kit

NOTE: 1" OD. steel bushing encased in 2" ID. EPDM rubber.

*For Non-stock items, minimum order quantities will apply.

10K General Duty Steel Hangers

2-1/2" WIDE SPRINGS

Each of the hanger sets below correspond to the steel fabricated equalizers on directly opposite page.

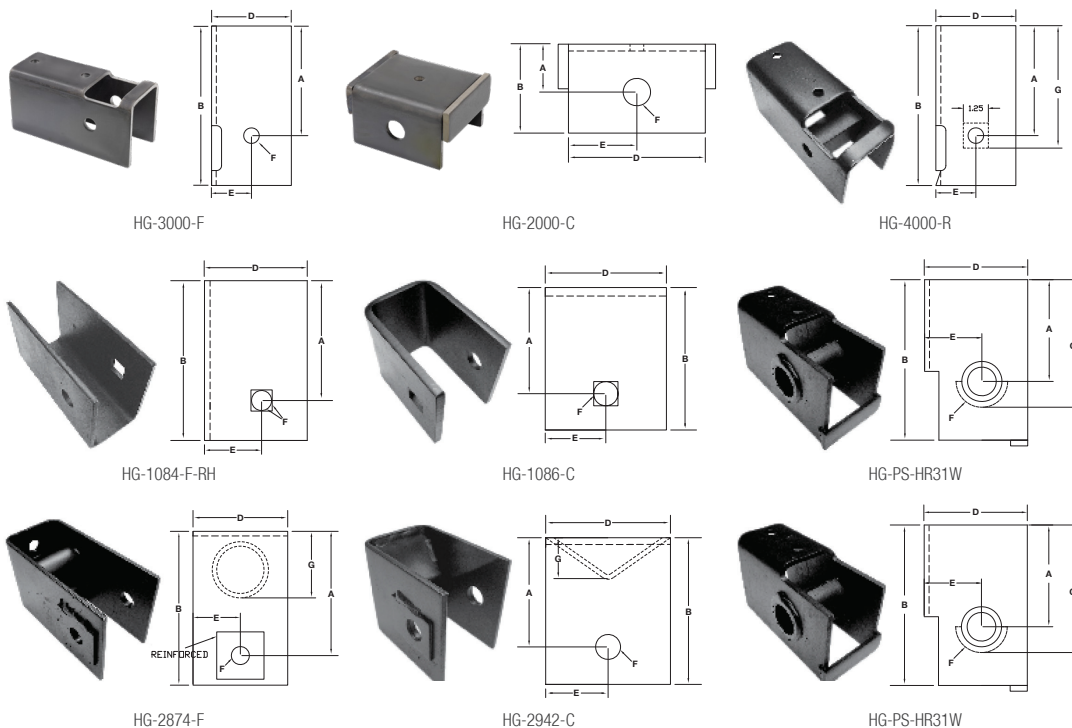

PART #	DIMENSIONS								REF #	UNIT WT.	CASE QTY.	CASE WT.
	A	B	C	D	E	F	G	t				
HG-3000-F	5.50"	8.00"	2.75"	4.00"	2.00"	0.78"	N/A	0.24"	3000	4.60 lb.	352 pc.	1,817 lb.
HG-2000-C	1.75"	3.19"	4.13"	5.00"	2.50"	1.00"	N/A	0.24"	2000	5.00 lb.	787 pc.	1,975 lb.
HG-4000-R	5.50"	8.00"	2.75"	4.00"	2.00"	N/A	6.13	0.24"	4000	5.80 lb.	264 pc.	2,291 lb.
HG-1084-F-LH	5.25"	7.00"	2.63"	4.50"	2.50"	0.77"	N/A	0.24"	72-1084	5.30 lb.	350 pc.	1,840 lb.
HG-1084-F-RH	5.25"	7.00"	2.63"	4.50"	2.50"	0.77"	N/A	0.24"	72-1084	5.30 lb.	350 pc.	1,840 lb.
HG-1086-C	4.38"	5.88"	3.25"	5.00"	2.50"	1.06"	N/A	0.37"	72-1086	7.23 lb.	350 pc.	2,530 lb.
HG-PS-HR31W	4.44"	7.00"	2.62"	4.50"	2.50"	2.25"	5.56	0.24"	72-1085	5.84 lb.	350 pc.	2,045 lb.
HG-2874-F	5.25"	6.50"	2.63"	4.00"	2.00"	0.76"	2.75	0.19"	28-74	4.30 lb.	330 pc.	1,420 lb.
HG-2942-C	4.25"	5.63"	3.25"	5.00"	2.50"	1.00"	1.75	0.24"	29-42	5.80 lb.	330 pc.	1,915 lb.

ADDITIONAL SPECS

- Material: High quality hot-rolled structural steel
- Dimension "C" = the inside width of the part
- Dimension "t" = thickness of material
- * See pg 78 for Tandem Axle Hanger Kit

*For Non-stock items, minimum order quantities will apply.

Suspension Fasteners

FABRICATED EQUALIZER BOLTS & NUTS

PART #	PACKAGED PARTS KIT#	DESCRIPTION	DIMENSIONS	BOX QTY.	BOX WT.
FA-7-1	PP-SBK-5	Bolt, Non-Lubed, CPH, GR2, Plain	7/8" - 9 x 4-11/16"	35 pc.	46 lb.
FA-7-1-1		Bolt, Lubed, no CPH, GR2, Plain	7/8" - 9 x 4-11/16"	35 pc.	46 lb.
FA-7-1-0		Bolt, Lubed, CPH, GR2, Plain	7/8" - 9 x 4-3/4"	35 pc.	46 lb.
FA-7-254		Bolt, Zinc, GR5, MIN 1" Full Thread	3/8" - 16 x 3-9/32"	325 pc.	37 lb.
FA-6-3		Nut, Slotted Hex, Plain	7/8" - 9	200 pc.	49 lb.
FA-6-111		Nut, Top Lock, Plain	7/8" - 9	360 pc.	54 lb.
FA-6-111Z		Nut, Top Lock, Zinc	7/8" - 9	300 pc.	54 lb.
FA-FLN375		Flanged Nut, Lock, Zinc	3/8" - 16	4,000 pc.	61 lb.



SHACKLE BOLTS & NUTS

PART #	PACKAGED PARTS KIT#	DESCRIPTION	DIMENSIONS	BOX QTY.	BOX WT.
FA-7-3	PP-SBK-1	Bolt, Hex, GR5, Plain	9/16" - 18 x 3"	120 pc.	43 lb.
FA-7-3Z		Bolt, Hex, GR5, Zinc	9/16" - 18 x 3"	120 pc.	43 lb.
FA-7-17	PP-SBK-2	Bolt, Hex, GR5, Plain	9/16" - 18 x 3-1/2"	110 pc.	51 lb.
FA-7-17Z		Bolt, Hex, GR5, Zinc	9/16" - 18 x 3-1/2"	110 pc.	51 lb.
FA-126A1LN		Bolt, Drilled Head, no Zerk, GR5, Plain	3/4" - 16 x 3-1/2"	130 pc.	52 lb.
FA-7-126	PP-SBK-3	Bolt, GR 5, Step Down Thread	7/16" - 20 x 2-9/10"	200 pc.	48 lb.
FA-126B2LN		Bolt, Lubed, Hex, GR5, Plain	9/16" - 18 x 3"	200 pc.	51 lb.
FA-7-236-1	PP-SBK-4	Bolt, Lubed, Hex, GR5, Step Down Thread	7/16" - 20 x 3-2/5"	130 pc.	37 lb.
FA-7-187		Bolt, Lubed, Hex, GR5, Step Down Thread	7/16" - 20 x 2-9/10"	130 pc.	37 lb.
FA-3416		Nut, Slotted for FA-126AILN	3/4" - 16	1,000 pc.	32 lb.
FA-916DLNZ		Nut, Top Lock, Zinc	9/16" - 18	550 pc.	56 lb.
FA-6-92Z		Nut, Flange, Steel Zinc, No Serrations	7/16" - 20	1,800 pc.	58 lb.
FA-6-1220Z		Nut, Flange, Steel Zinc	1/2" - 20	700 pc.	32 lb.



• See Packaged Parts starting on pg 72

Suspension Fasteners

LEAF SPRING CENTER BOLTS

PART #	DESCRIPTION	DIMENSIONS	BOX QTY.	BOX WT.
FA-LSB225	Bolt, Spring Retainer	3/8" – 24 x 2-1/4"	500 pc.	40 lb.
FA-LSB325	Bolt, Spring Retainer	3/8" – 24 x 3-1/4"	500 pc.	52 lb.
FA-LSB400	Bolt, Spring Retainer	3/8" – 24 x 4"	500 pc.	60 lb.
FA-LSN375	Nut, Hex for Spring Retainer Bolt	3/8" - 24 x 3-3/4"	950 pc.	40 lb.



MISCELLANEOUS FASTENERS

PART #	PACKAGED PARTS KIT#	DESCRIPTION	DIMENSIONS	BOX QTY.	BOX WT.
FA-7-112		Press in Brake Stud, GR5 Nut	3/8" - 24 x 7/8"	1,800 pc.	36 lb.
FA-6-058		Flange Wheel, Zinc, GR8 Wheel	5/8" - 18	150 pc.	41 lb.
FA-7-40X		Bolt, Hex Head	1/2" - 20 x 1-5/8"	220 pc.	51 lb.
FA-6-080	PP-WNK-1	Wheel Nut, 60 Degree, GR5, Zinc	1/2" - 20	550 pc.	60 lb.
FA-6-053	PP-WNK-2	Wheel Nut, 60 Degree, GR5, Zinc	9/16" - 18	600 pc.	47 lb.
FA-6-176		Spindle Nut, 12 Slot	1" - 14	270 pc.	47 lb.
FA-6-109	PP-WNK-3	Wheel Nut, 90 Degree, GR8, Zinc	5/8" - 18	300 pc.	32 lb.
FA-WN-M22-1530		Wheel Nut M22 for 16K Idler Hub Stud	1-1/2" x 30 mm	120 pc.	20 lb.
FA-WS-2000	PP-WSK-1	Wheel Stud, GR8, Yellow Zinc	1/2" - 18 x 2"	100 pc.	18 lb.
FA-WS-2310	PP-WSK-2	Wheel Stud, GR8, .617 OD Knurl, Yellow Zinc	9/16" - 18 x 2-5/16"	250 pc.	45 lb.
FA-WS-HW246		Wheel Stud, Idler Hubs	1/2" - 20 x 2"	400 pc.	55 lb.
FA-WS-2750	PP-WSK-3	Wheel Stud, 175705, .689 OD Knurl, ZN	5/8" - 18 x 2-3/4"	160 pc.	40 lb.
FA-WS-2310-689	PP-WSK-4	Wheel Stud, 175704, GR8 .689 OD Knurl, ZN	5/8" - 18 x 2-5/16"	240 pc.	45 lb.
FA-WS-3440	PP-WSK-5	Wheel Stud, 183128, .689 OD Knurl, ZN	5/8" - 18 x 3-7/16"	160 pc.	35 lb.
FA-38-875		10" Backing Plate Stud, .53 Knurl, ZN	7/16" x 3/4"	160 pc.	30 lb.
FA-352774	PP-WSK-6	16K Wheel Stud, GR8, 1.007 Knurl, ZN	M22 x 1-1/2" x 4-4/5"	60 pc.	60 lb.



Other suspension fasteners available upon request

Mobile Home Axle Products

TRP International continues to lead the industry with a full range of mobile home axle and suspension products.



Spring Seat



Bearing



Idler Hub



Spring Hanger



Dust Cap



Equalizer



U-Bolt Tie Plate

PART #	TYPE	CASE QTY.
DE-7240	Single Leaf Spring	440 pc.
DE-7226	Multiple Leaf Spring	200 pc.
EQ-104	Equalizer	1,000 pc.
DC-250	Dust Cap	360 pc.
SL-200	2.00" Shackle Link	5,000 pc.
SL-225	2.25" Shackle Link	5,000 pc.
HG-100	1.00" Spring Hanger	2,500 pc.
HG-144	1.44" Spring Hanger	2,500 pc.
HG-246	2.46" Spring Hanger	1,250 pc.
HG-325	3.25" Spring Hanger	1,250 pc.
TP-300175	3.00" Axle Tube U-Bolt Tie Plate	2,500 pc.
SS-300	3.00" Axle Tube Spring Seat Grease	2,500 pc.
GS-1938NYL	Nylon Seal, 1.938" Shaft	500 pc.
L-68149	Inner Bearing Cone	6,624 pc.
L-68111	Inner Bearing Cup	6,624 pc.

• See product page for complete dimensional descriptions and industry reference numbers

*For Non-stock items, minimum order quantities will apply.



Shackle Link



Brake Drum

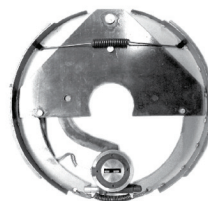

Electric Brake



Outer Bearing Cone



Single Leaf Spring



Multiple Leaf Spring



Spindle



Outer Bearing Cup

PART #	TYPE	CASE QTY.
LM-67048	Outer Bearing Cone	6,624 pc.
LM-67010	Outer Bearing Cup	6,624 pc.
MHI-122458-RCB	Idler Hub With Rim Clamps And Bolts	150 pc.
MHD-122459-RCB	Brake Drum With Rim Clamps And Bolts	81 pc.
BK-12E-MHL-01	12" Electric Brake With Magnet, Left Hand	240 pc.
BK-12E-MHL-02	12" Electric Brake With Magnet, Right Hand	240 pc.
SP-122457	Hot Forged Butt Weld Style Spindle	1,350 pc.

Mobile Home Rim Clamp

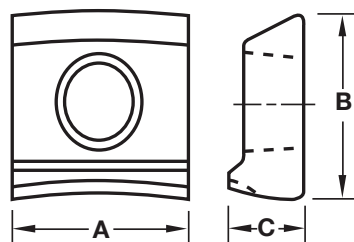

PART #	DIMENSIONS			CASE QTY.	CASE WT.
	A	B	C		
FA-1512	1.26"	1.36"	0.54"	15,000 pc.	2,100 lb.

The specifications and dimensions above are for reference only. *Also available galvanized, call for availability and pricing.

TRP MARINE PRODUCTS

In this section, you will find our growing offering of marine products. With superior engineering, innovative technology and decades of experience, we work to help find what you need. Many of our parts are available to be coated for marine applications.

MARINE PRODUCTS



Galvanized Idler Hubs

RV1-H-655-HDG



PART #	DESCRIPTION				UNIT WEIGHT	CASE QUANTITY	CASE WEIGHT
	AXLE CAP.	BOLT DIAM.	INNER RACE	OUTER RACE			
RVI-BT-5450-HDG	2,500 lb.	5 on 4.50"	L-44610	L-44610	6.43 lb.	294 pc.	1,945 lb.
RVI-U-5450-HDG	3,500 lb.	5 on 4.50"	L-68111	L-44610	7.20 lb.	294 pc.	2,170 lb.
RVI-U-5475-HDG	3,500 lb.	5 on 4.75"	L-68111	L-44610	7.50 lb.	216 pc.	1,670 lb.
RVI-U-5500-HDG	3,500 lb.	5 on 5.00"	L-68111	L-44610	7.80 lb.	216 pc.	1,740 lb.
RVI-U-5550-HDG	3,500 lb.	5 on 5.50"	L-68111	L-44610	9.45 lb.	180 pc.	1,751 lb.
RVI-U-6550-HDG	3,500 lb.	6 on 5.50"	L-68111	L-44610	9.60 lb.	180 pc.	1,780 lb.
RVI-H-655-HDG	6,000 lb.	6 on 5.50"	25520	15245	13.74 lb.	150 pc.	2,110 lb.
RVI-H-655-HDG-LS	6,000 lb.	6 on 5.50"	25520	15245	14.00 lb.	150 pc.	2,150 lb.
RVI-H-865-HDG	7,000 lb.	8 on 6.50"	25520	14276	17.03 lb.	125 pc.	2,180 lb.
RVI-H-865-HDG-LS	7,000 lb.	8 on 6.50"	25520	14276	17.50 lb.	125 pc.	2,250 lb.
RVI-H-865-916-HDG	7,000 lb.	8 on 6.50"	25520	14276	17.50 lb.	125 pc.	2,250 lb.

ADDITIONAL SPECS

- Manufactured to automotive standards in ISO/TS-16949 registered factory
- Studs are 1/2" - 20 with zinc plating. (RVI-H-865-916 studs are 9/16" - 18)
- LS= Long Studs, 1/2"-20 x 2.625", for stronger clamping force and better wheel retention
- Fully integrated casting, machining, painting, and assembly operations
- ASTM test bar method used to monitor tensile strength

Winches

HAND WINCHES

PART #	DESCRIPTION	UNIT WT.	BOX QTY.	BOX WT	BOXES PER SKID	REF. #
TR-WH1K	Single-Speed Trailer Winch, 1,000 lb. Capacity, Zinc Plated	5.51 lb.	6 pc.	37 lb.	25 pc.	HW-1000
TR-WH1.4K	Single-Speed Trailer Winch, 1,400 lb. Capacity, Zinc Plated	5.86 lb.	6 pc.	40 lb.	25 pc.	HW-1400
TR-WH1.6K	Single-Speed Trailer Winch, 1,600 lb. Capacity, Zinc Plated	7.72 lb.	4 pc.	29 lb.	30 pc.	HW-1600
TR-WH2K	Two-Speed Trailer Winch, 2,000 lb. Capacity, Zinc Plated	8.27 lb.	4 pc.	35 lb.	30 pc.	HW-2000

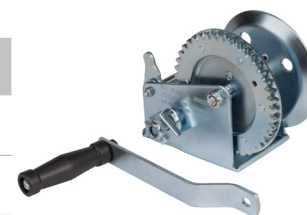

BRAKE WINCHES

PART #	DESCRIPTION	UNIT WT.	BOX QTY.	BOX WT	BOXES PER SKID	REF. #
TR-WB1K	Self-Activating Brake Winch, 1,000 lb. Capacity, Zinc Plated	5.51 lb.	6 pc.	37 lb.	25 pc.	BW-1000
TR-WB1.5K	Self-Activating Brake Winch, 1,500 lb. Capacity, Zinc Plated	7.50 lb.	6 pc.	50 lb.	25 pc.	BW-1400

Marine Products

GALVANIZED EQUALIZER SPRINGS

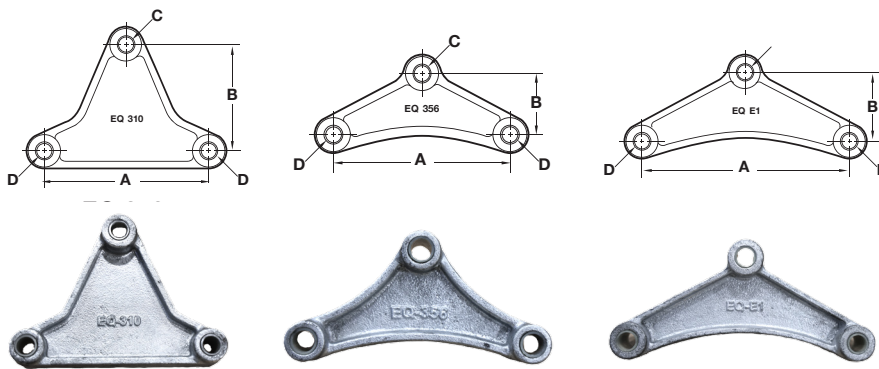

PART #	DIMENSIONS				UNIT WT.	CASE QTY.	CASE WT.
	A	B	C	D			
EQ-310Z - Galvanized	6.06"	4.00"	0.563"	0.563"	2.85 lb.	630 pc.	2,000 lb.
EQ-356Z - Galvanized	6.13"	2.50"	0.563"	0.563"	2.25 lb.	1,000 pc.	2,320 lb.
EQ-E1Z - Galvanized	7.75"	2.88"	0.563"	0.563"	2.75 lb.	700 pc.	2,100 lb.

LEAF SPRINGS



PART #	DESCRIPTION	PALLET QTY.	PALLET WT.
S0-C3-PC	3-Leaf Spring Slip Open 1750# 26.25"; Powder Coated	200 pc.	2,428 lb.
S0-C4-PC	4-Leaf Spring Slip Open 1750# 26.25"; Powder Coated	200 pc.	2,974 lb.
S0-C5-PC	5-Leaf Spring Slip Open 1750# 26.25"; Powder Coated	150 pc.	2,613 lb.
DE-SW5-PC	5-Leaf Double Eye Spring 2900# 25.25"; Powder Coated	180 pc.	2,038 lb.
DE-SW3-PC	3-Leaf Double Eye Spring 1750# 25.25"; Powder Coated	300 pc.	2,340 lb.
DE-SW4-PC	4-Leaf Double Eye Spring 2500# 25.25"; Powder Coated	200 pc.	2,760 lb.
SF-434117-PC	4-Leaf Spring Slip Flat 2000# 30.00"; Powder Coated	200 pc.	2,440 lb.

*Any spring can be special ordered in full skid quantities with marine powder coating

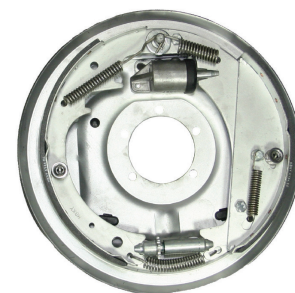

HYDRAULIC BRAKES

PART #	DESCRIPTION	UNIT WEIGHT	CASE QTY.	CASE WEIGHT
BK-40715X	RH, 10" Free Backing, Dacromet	9.59 lb.	156 pc.	1,602 lb.
BK-40716X	LH, 10" Free Backing, Dacromet	9.59 lb.	156 pc.	1,602 lb.
BK-42028X	RH, 12" Free Backing, Dacromet	14.66 lb.	117 pc.	1,822 lb.
BK-42029X	LH, 12" Free Backing, Dacromet	14.66 lb.	117 pc.	1,822 lb.

MARINE PRODUCTS

TruRyde Disc Brake Kits

3.5K

5 LUG 1/2" STUDS, INTEGRATED ROTOR
ZINC OR E-COAT FINISH



PART #	DESCRIPTION
DBI-3.5K-TR-ECOAT (Complete Kit)	TruRyde 3.5K Disc Kit, (2) Black E-Coat Integrated Rotors, and (2) Clear Zinc Calipers w/ Pads
DBI-3.5K-TR-ZINC (Complete Kit)	TruRyde 3.5K Disc Kit, (2) Clear Zinc Integrated Rotors, and (2) Clear Zinc Calipers w/ Pads
RTR/HUB-975-TR-ECOAT	9.75" RTR/HUB, 5-Lug Integrated 1/2" WS, E-Coat
RTR/HUB-975-TR-ZINC	9.75" RTR/HUB, 5-Lug Integrated , 1/2" WS, Zinc
CALP-3-6K-TR-ZINC	3-6K Caliper, Zinc w/ Pads

6K

6 LUG 1/2" STUDS, INTEGRATED ROTOR
ZINC OR E-COAT FINISH



PART #	DESCRIPTION
DBI-6K-TR-ECOAT (Complete Kit)	TruRyde 6K Disc Kit, (2) Black E-Coat Integrated Rotors, (2) Top Mount E-Coat Brackets, and (2) Clear Zinc Calipers w/ Pads
DBI-6K-TR-ZINC (Complete Kit)	TruRyde 6K Disc Kit, (2) Clear Zinc Integrated Rotors, (2) Top Mount Clear Zinc Brackets, and (2) Clear Zinc Calipers w/ Pads
DBI-6K-TR-SM-ECOAT (Complete Kit)	TruRyde 6K Disc Kit, (2) Black E-Coat Integrated Rotors, (2) Side Mount E-Coat Brackets, and (2) Clear Zinc Calipers w/ Pads
DBI-6K-TR-SM-ZINC (Complete Kit)	TruRyde 6K Disc Kit, (2) Clear Zinc Integrated Rotors, (2) Side Mount Clear Zinc Brackets, and (2) Clear Zinc Calipers w/ Pads
RTR/HUB-1177-TR-ECOAT	11.77" RTR/HUB, 6-Lug Integrated, 1/2" WS, E-Coat
RTR/HUB-1177-TR-ZINC	11.77" RTR/HUB, 6-Lug Integrated, 1/2" WS, Zinc
CALP-3-6K-TR-ZINC	3-6K Caliper, Zinc w/ Pads
DBB-6K-TR-ECOAT	6K Bracket, E-Coat, Top Mount
DBB-6K-TR-ZINC	6K Bracket, Zinc, Top Mount
DBB-6K-TR-SM-ECOAT	6K Bracket, E-Coat, Side Mount
DBB-6K-TR-SM-ZINC	6K Bracket, Zinc, Side Mount

ADDITIONAL SPECS

- Non-handed Caliper; less inventory requirement
- Inlet & Outlet Ports at 45 degree angle; more efficient bleeding system
- Vented Rotor; better airflow for a cooler unit, allows water to escape

*One kit required per axle.

The specifications and dimensions above are for reference only.

DeeMaxx Disc Brake Kits

3.5K

5 LUG 1/2" STUDS, INTEGRATED OR SLIP OVER ROTOR

PART #	DESCRIPTION
DBI-3.5K-MAXX RTR/HUB-102-MAXX CALP-3-6K-MAXX DBB-3.5KI-MAXX CALP-3-6K-BRAKE PAD	Integrated Kit Contains Rotor/Hubs, Calipers And Brackets For One Axle
DBSO-3.5K-MAXX RTR-109-MAXX CALP-3-6K-MAXX DBB-3.5K-MAXX CALP-3-6K-BRAKE PAD	Slip Over Kit Contains Rotor/Hubs, Calipers And Brackets For One Axle

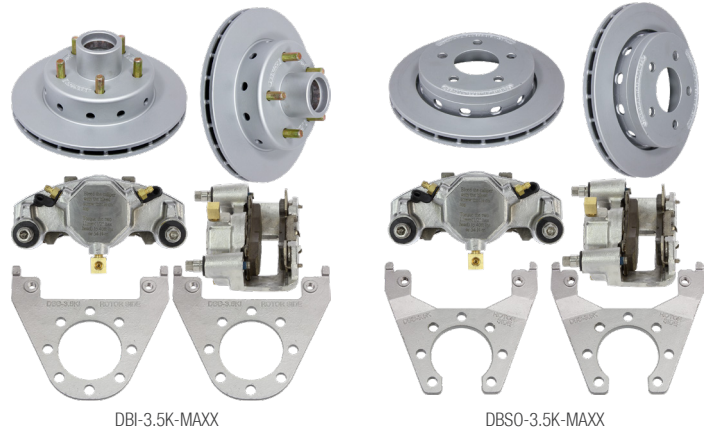

6K

6 LUG 1/2" STUDS, INTEGRATED OR SLIP OVER ROTOR

PART #	DESCRIPTION
DBI-6K-MAXX RTR/HUB-120-MAXX CALP-3-6K-MAXX DBB-6K-MAXX CALP-3-6K-BRAKE PAD	Integrated Kit Contains Rotor/Hubs, Calipers And Brackets For One Axle
DBSO-6K-MAXX RTR-120-MAXX CALP-3-6K-MAXX DBB-6K-MAXX CALP-3-6K-BRAKE PAD	Slip Over Kit Contains Rotor/Hubs, Calipers And Brackets For One Axle

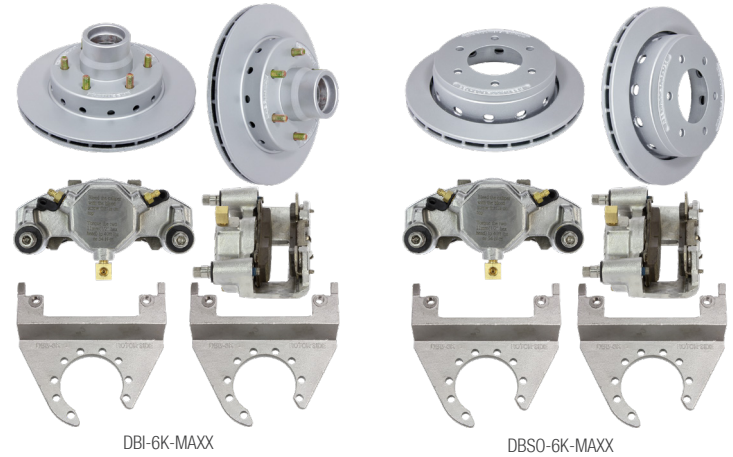

7K

8 LUG 1/2", 9/16", 5/8" STUDS, INTEGRATED OR SLIP OVER ROTOR

PART #	DESCRIPTION
DBI-7K-MAXX RTR/HUB-131-7K-MAXX CALP-7-8K-MAXX DBB-7K-MAXX CALP-7-8K-BRAKE PAD	Integrated Kit Contains Rotor/Hubs, Calipers And Brackets For One Axle
DBSO-7K-MAXX RTR-131-7K-MAXX CALP-7-8K-MAXX DBB-7K-MAXX CALP-7-8K-BRAKE PAD	Slip Over Kit Contains Rotor/Hubs, Calipers And Brackets For One Axle
DBI-7K-9-MAXX RTR/HUB-131-8K-.56-MAXX CALP-7-8K-MAXX DBB-7K-MAXX CALP-7-8K-BRAKE PAD	Integrated Kit Contains Rotor/Hubs, Calipers And Brackets For One Axle
DBI-7K-10-MAXX RTR/HUB-131-8K-.62-MAXX CALP-7-8K-MAXX DBB-7K-MAXX CALP-7-8K-BRAKE PAD	Integrated Kit Contains Rotor/Hubs, Calipers And Brackets For One Axle

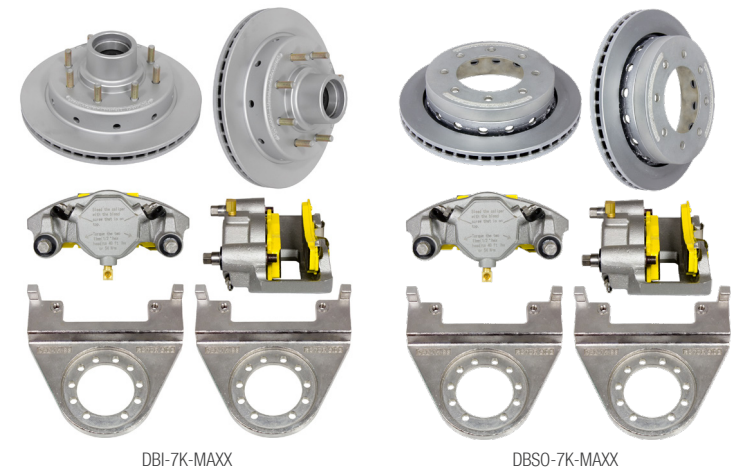

*One kit required per axle.

**Optional Yellow Zinc Plated finish is available by replacing "MAXX" with "GOLD" on the kit part number and caliper part number

8K

8 LUG 9/16" STUDS, INTEGRATED OR SLIP OVER ROTOR
 8 LUG 5/8" STUDS, INTEGRATED OR SLIP OVER ROTOR
 MAXX OR GOLD FINISH

INTEGRATED NON-THREADED (GREASE)

PART #	DESCRIPTION
DBI-8KD9-NT-MAXX RTR/HUB-131-8KNT-.56-MAXX CALP 7-8K-MAXX w/HH PADS DBB-8KD-MAXX	One Axle Set Of Integral 8,000lb Maxx Coating Disc Brakes. 9/16" Studs
DBI-8KD10-NT-MAXX RTR/HUB-131-8KNT-.62-MAXX CALP 7-8K-MAXX w/HH PADS DBB-8KD-MAXX	One Axle Set Of Integral 8,000lb Maxx Coating Disc Brakes. 5/8" Studs
DBI-8KA10-NT-MAXX RTR/HUB-131-8KNT-.62-MAXX CALP 7-8K-MAXX w/HH PADS DBB-8KA-MAXX	One Axle Set Of Integral 8,000lb Maxx Coating Disc Brakes. 5/8" Studs

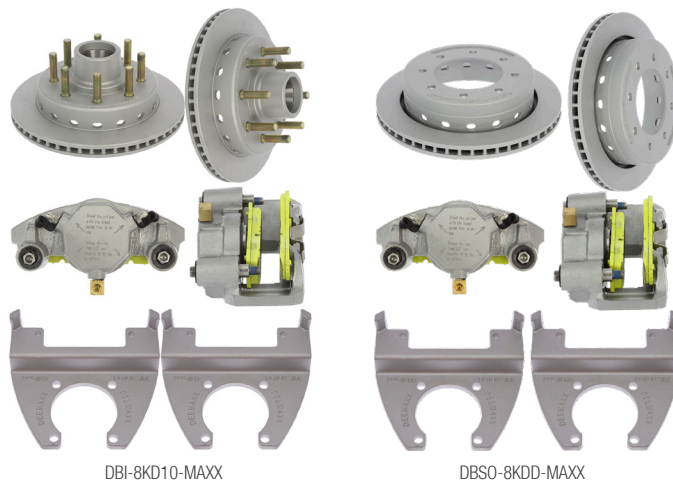

DBI-8KD10-MAXX

DBSO-8KDD-MAXX

INTEGRATED THREADED (OIL)

PART #	DESCRIPTION
DBI-8KD9-T-MAXX RTR/HUB-131-8KT-.56-MAXX CALP 7-8K-MAXX w/HH PADS DBB-8KD-MAXX	One Axle Set Of Integral 8,000lb Maxx Coating Disc Brakes. 9/16" Studs
DBI-8KD10-T-MAXX RTR/HUB-131-8KT-.62-MAXX CALP 7-8K-MAXX w/HH PADS DBB-8KD-MAXX	One Axle Set Of Integral 8,000lb Maxx Coating Disc Brakes. 5/8" Studs

SLIP OVER

PART #	DESCRIPTION
DBSO-8KDD-MAXX RTR/HUB-131-8K-MAXX CALP 7-8K-MAXX w/HH PADS DBB-8KDD-MAXX	One Axle Set Of Slip Over 8,000lb Maxx Coating Disc Brakes. Can Be Used With 5/8" Or 9/16" Studs *Must Use Dexter Or Deemaxx Disc Idler Hub
DBSO-8KA-MAXX RTR/HUB-131-8K-MAXX CALP 7-8K-MAXX w/HH PADS DBB-8KA-MAXX	One Axle Set Of Slip Over 8,000lb Maxx Coating Disc Brakes. Can Be Used With 5/8" Or 9/16" Studs *Must Use Axis/Alko Or Rockwell Disc Idler Hub

Single Wheel Disc Brakes

10-12K



DBI-10KDL-SW-MAXX



DBI-10KAAQ-MAXX

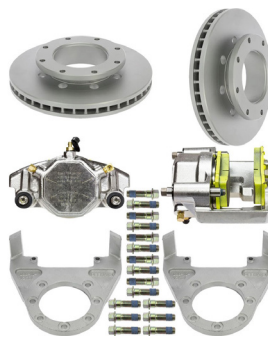

DBSO-10-12KDL-SW-MAXX

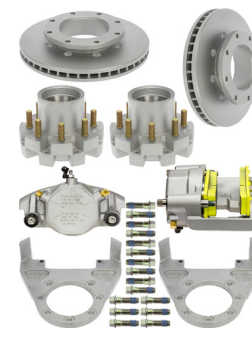

DBI-12KDL-SW-MAXX

One (Axle) Set Of Integral 10,000 lb Maxx Disc Brakes For Dexter/Lippert Spindle
 Includes Maxx Integral 13" Rotor, Maxx Caliper W Sm Pads, Maxx Bracket & Hub Mounting Bolts
 * Fits 16" Single Wheel Application W/ 5/8" Wheel Studs - Uses 387A Inner/25580 Outer Bearings.

One (Axle) Set Of Integral 10,000 lb Maxx Disc Brakes For Alko/Quality #99 Spindle
 Includes Maxx Integral 13" Rotor, Maxx Caliper W Pads, Maxx Bracket & Hub Mounting Bolts * Fits 17.5" Single Wheel Application W/ 5/8" Wheel Studs - Uses 28580 Inner /25580 Outer Bearings

One (Axle) Set Of 12,000 lb Maxx Disc Brakes For Dexter/Lippert #14T Spindle
 Includes 16-Rtr-Bolt 1/2-13 X 1.5" For 13" Rtr/Spc, Maxx Caliper W/Pads, Maxx Bracket And Hub Mounting Bolts
 Uses 3984 Inner/28682 Outer Bearings

One (Axle) Set Of Integral 12,000 lb Maxx Disc Brakes For Dexter/Lippert Spindle
 Includes Maxx Integral 13" Rotor, Maxx Caliper W Sm Pads, Maxx Bracket & Hub Mounting Bolts
 Uses 3984 Inner/28682 Outer Bearings.

The specifications and dimensions above are for reference only.

Dual Wheel Disc Brakes

9-16K

PART #	DESCRIPTION
DBI-10KDL-DW-MAXX	One Axle set of Integral 10,000 lb. Maxx Coating Disc Brakes for Dexter/Lippert Spindle With 5.25" Inner Bearing shoulder to Brake Flange. Use 387A Inner / 25580 Outer Bearing Includes Hub, 32-RTR-Bolt 1/2-13 x 1.5" for 13" Rotor/Sp, Zinc Caliper w/ SM Pads, AND Zinc Bracket (7 Bolt) *Fits 16" Dual Wheel Wheel Application w/ 5/8" Wheel Studs
DBI-12KDL-DW-MAXX	One Axle set of Integral 12,000 lb. Maxx Coating Disc Brakes for Dexter/Lippert Spindle With 5.25" Inner Bearing shoulder to Brake Flange. Use 3984 Inner / 28682 Outer Bearing Includes Hub-12KDL, 32-RTR-Bolt 1/2-13 x 1.5" for 13" Rotor/Sp, Zinc Caliper w/ Black SM Pads, AND Zinc Bracket (7 Bolt) *Fits 16" Dual Wheel Wheel Application w/ 5/8" Wheel Studs
DBI-16KDL-DW-MAXX	One Axle set of Integral 16,000 lb. Maxx Coating Disc Brakes for Dexter/Lippert Spindle. Use 3984 Inner / 28682 Outer Bearing Includes Hub-16KDL, 32-RTR-Bolt 1/2-13 x 1.5" for 13" Rotor/Sp, Zinc Caliper w/ Black SM Pads, and Zinc Bracket (7 Bolt) *Fits 16" Dual Wheel Application w/ M22 Wheel Studs
DBB-10-16KDL-DW-ZINC	Disc Brake Bracket for 7 hole brake flange 10-16K Dexter/Lippert Dual Wheel Axle fits 11" Rotor, Zinc Coating
CALP-10-16KDW-ZINC	Disc Brake Bracket for 10-16K Axle Dual Wheel 2 - Piston Zinc Plated with Green Semi-metallic Brake Pads
RTR-11-10-16KDL-DW-MAXX	11" Bolt-on rotor for Dexter/Lippert with (8) 1" and (8) - .530" holes Maxx fits HUB-9-16K
RTR-10-16K-BOLT	Bolt, 1/2-13 x 1.5", 6 pt Hex w/flange Grade 8 Yellow Zinc Plated 3M22352 w/Blue Loctite, Torque Bolt to Rotor at 80 ft. lb.
HUB-11-10-16KDL-DW-SPCR-MAXX	Spacer for 11" Bolt on Rotor for Dexter/Lippert with 8 - 1/2" - 13UNC-2B and 8 - .530" holes, Maxx fits Hub 9-16K
RVI-10K-865-580	8 on 6.5" 10K Dexter/Lippert Oil Hub 4.75" Pilot, 25520 (Outer) and 382A (Inner) Bearing races and (Yellow) 5/8"-18 Wheel Studs DX# 008-288-03 9-10K GD Use 387A (Inner) and 25580 (Outer) Bearing
RVI-12K-865-580	8 on 6.5" 12K Dexter/Lippert Oil Hub 4.75" Pilot, Inner Bearing 3984 Cup/Race 3920 and Outer Bearing 28682 Cup/Race 28622 DX# 008-214-10
RVI-16K-8275-M22	8 on 275 mm M22 Wheel Studs 16K Dexter/Lippert Oil Hub, Inner Bearing 3984 Cup/Race 3920 and Outer Bearing 28682 Cup, Race 28622 DX# 088-401-05

ADDITIONAL SPECS

- Fits 16" Dual Wheel or larger
- All parts are non-handed (L or R)
- Laser writing on caliper for bleeding instructions and torque specifications



DBI-12KDL-DW-MAXX

**UNIQUE BRACKET
DESIGN PROVIDES
TWICE AS MANY
MOUNTING OPTIONS
FOR CALIPER
POSITION**

**EVERY
CALIPER IS
TESTED TO
2000 PSI**

**120°
BLEEDER
DESIGN**

- Better bleeding
- Balanced system
- No more damaged bleeders

**PASSED THE
SAE J2681
BRAKE TEST**

High Performance Brake Lines



RUBBER BRAKE LINES

DOT-RFL-12"	DOT-RFL-16"	DOT-RFL-18"	DOT-RFL-24"	DOT-RFL-36"	DOT-RFL-38"	DOT-RFL-60"
DOT-RFL-72"	DOT-RFL-78"	DOT-RFL-220"	DOT-RFL-240"	DOT-RFL-260"	DOT-RFL-280"	DOT-RFL-312"

STAINLESS STEEL BRAKE LINES

DOT-SSFL-18"	DOT-SSFL-24"	DOT-SSFL-30"	DOT-SSFL-36"
--------------	--------------	--------------	--------------

BRAKE LINE ASSEMBLIES DESCRIPTION

DOT-BF3W	3 way 3 1/16" inverted flare inlets
DOT-BF4W	4 way 3 1/16" inverted flare inlets
DOT-BF90	90 degree elbow 3/16" inverted flare inlets
DOT-BFUNION	Coupler with 3 1/16" inverted flare inlets
DOT-HMC	Hose Mount, Clamp, Neoprene Cushioned, 304 SS, .375 in. O.D. Hose
DOT-NCTIE	Black UV protected nylon, self locking axle tie with slip prevention locking to secure brake lines to axle.
DOT-SSSDS	Stainless Steel Self Drilling Screw w/ Indented Hex Washer 6mm x 24 mm Indented Hex Washer #3 drill point 2/8" Hex Head

DeeMaxx Brake Line Kits

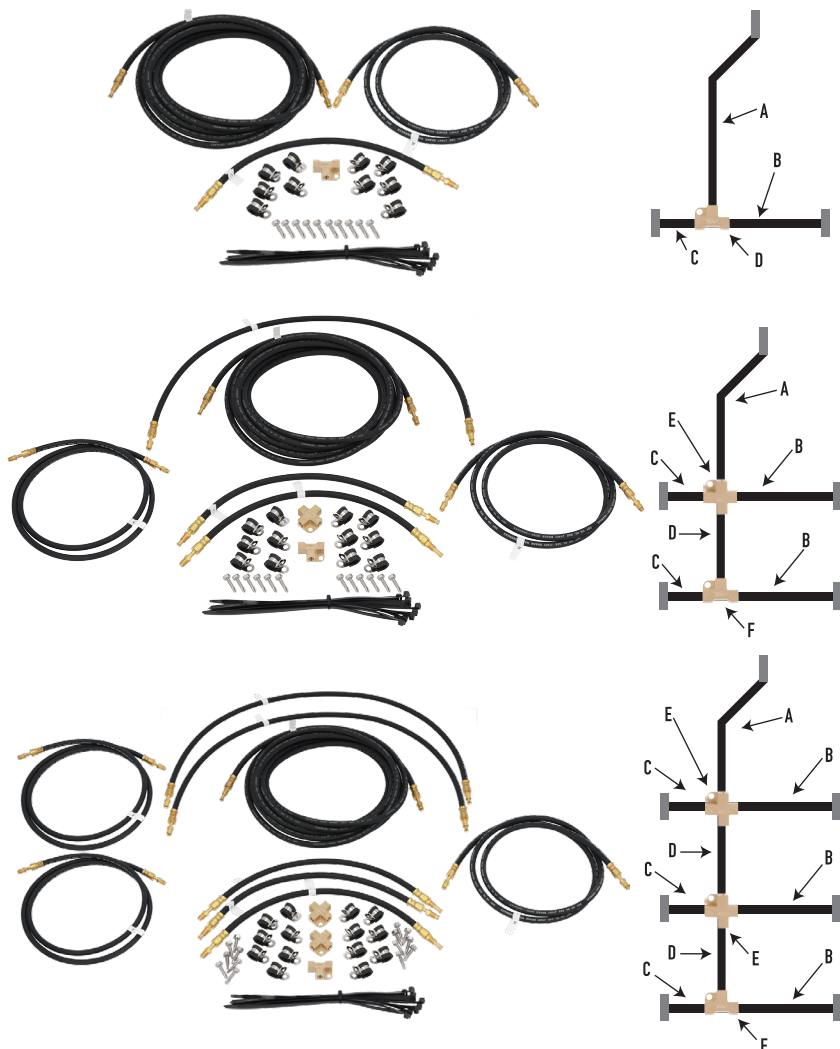

18' SINGLE AXLE BRAKE LINE KIT (DOT-SA18K)

DOT-SA18K CONTENTS:

- A - (1) 220" long flexible trailer brake line
- B - (1) 72" long flexible trailer brake line
- C - (1) 18" long flexible trailer brake line
- D - (1) Brass 3 way 'T' fitting (mounting screw included)
- (10) Brake Line Clamps 10 mounting screws included)
- (6) Axle Tie Straps

20' TANDEM AXLE BRAKE LINE KIT (DOT-TA20K)

DOT-TA20K CONTENTS

- A - (1) 240" long flexible trailer brake line
- B - (2) 72" long flexible trailer brake line
- C - (2) 18" long flexible trailer brake line
- D - (1) 36" long flexible trailer brake line
- E - (1) Brass "4 way" fitting
- F - (1) Brass 3 way 'T' fitting (mounting screw included)
- (12) Brake Line Clamps (12 mounting screws included)
- (12) Axle Tie Straps

20' TRIPLE AXLE BRAKE LINE KIT (DOT-TR20K)

DOT-TR20K CONTENTS

- A - (1) 240" long flexible trailer brake line
- B - (3) 72" long flexible trailer brake line
- C - (3) 18" long flexible trailer brake line
- D - (2) 36" long flexible trailer brake line
- E - 2) Brass "4 way" fittings (mounting screws included)
- F - (1) Brass 3 way 'T' fitting (mounting screw included)
- (14) Brake Line Clamps (14 mounting screws included)
- (18) Axle Tie Straps

The specifications and dimensions above are for reference only.

Brake Actuators

ELECTRIC-OVER-HYDRAULIC

DeeMaxx/Deutsche Hydrapro™ developed their Hydrapro Electric Over Hydraulic (EOH) Brake Actuator with a global German hydraulic pump manufacturer with over 90 years of experience providing innovative hydraulic drive and control technologies.

Our electric-over-hydraulic brake actuator's quality and simplicity gives you the necessary reliability for a trailer braking system. In addition, it has a superior response time that delivers shorter stopping distances, which gives the driver confidence while towing. DeeMaxx is the only company that offers 360° brake line position connection,



ANODIZED, T6-GRADE EXTRUDED ALLOY HOUSING

protects from different environments

INDEPENDENTLY SEALED FLUID TANK

provides extra fluid reserves

3X LONGER LASTING DURABILITY IN EXTREME TESTING

PART #	DESCRIPTION
TR-EOHA1600X	1600 psi w/ Larger Fluid Capacity 28.7 oz.
TR-EOHA1600	1600 psi for Disc Brakes
TR-EOHA1200	1200 psi for Drum Brakes w/ 8k or Higher Axles
TR-EOHA1000	1000 psi for Drum Brakes w/ 8k or Lower Axles



TR-EOHA1600



HIGH-POWERED DC MOTOR

with minimal moving parts for reliability

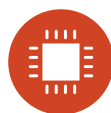

ROBUST ELECTRONICS BOARD

with protective coating for corrosion resistance



2-YEAR WARRANTY

giving you peace of mind

SURGE

PART #	DESCRIPTION
TR-AS7K-2.00-WO-DISC	7K, 2" Ball, Weld-On, Disc
TR-AS8.4K-2.00-WO-DISC	8.4K, 2" Ball, Weld-On, Disc



TR-AS7K-2.00-WO-DISC

TR-AS8.4K-2.00-WO-DISC

Jacks



TR-JSWWM1K-10



TR-JSWBMD1.5K-10



TR-JSWBM1.2K-10

PART #	MOUNTING PLATE #	LIFT CAP.	DESCRIPTION	UNIT WT.	CASE QTY.	CASE WT.	REF. #
TR-JSWWM1K-10	TR-AMJMBK-1K	1,000 lb.	Side Wind Swivel, Weld-On, w/6" Caster	13.20 lb.	150 pc.	2,020 lb.	MJ-1000W
TR-JSWBM1.2K-10	TR-AMJMBK-1.2K	1,200 lb.	Side Wind Swivel, Bolt-On, w/6" Caster	14.70 lb.	120 pc.	1,801 lb.	MJ-1200B
	TR-AMJMBK-1.5K*						
TR-JSWBM1.5K-10	TR-AMJMBK-1.5K	1,500 lb.	Side Wind Swivel, Bolt-On, w/8" Caster	19.10 lb.	100 pc.	1,950 lb.	MJ-1500B
TTR-JSWBMD1.5K-10	TR-AMJMBK-1.5K	1,500 lb.	Side Wind Swivel, Bolt-On, w/6" Dual Caster	19.60 lb.	90 pc.	1,804 lb.	MJ-1500B-DWL
TR-JSWFBM2.5K-28	N/A (welded)	2,500 lb.	Square Side Wind Fixed, Bolt-On, w/jack Ft	25.70 lb.	100 pc.	2,610 lb.	MJSQ-2500B
TR-AMJMBK	Replacement Marine Jack Mounting Bracket Kit						

Replacement Marine Handles

PART #	DESCRIPTION	REF #
TR-AMJHSW-1K	Replacement Marine Jack Handle for Side Wind, 1K	MJ-1000B-HD
TR-AMJHSW-1.2K	Replacement Marine Jack Handle for Side Wind, 1.2K	MJ-1200B-HD
TR-AMJHSW-1.5K	Replacement Marine Jack Handle for Side Wind, 1.5K	MJ-1500B-HD



Replacement Marine Mounting Brackets

PART #	DESCRIPTION	REF #
TR-AMJMBK-1K	Replacement Marine Jack Mounting Bracket Kit, 1K	MJ-1000B-MK
TR-AMJMBK-1.2K	Replacement Marine Jack Mounting Bracket Kit, 1.2K	MJ-1200B-MK
TR-AMJMBK-1.5K	Replacement Marine Jack Mounting Bracket Kit, 1.5K	MJ-1500B-MK

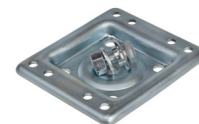

TR-AMJMBK-1K

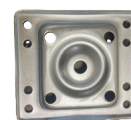

TR-AMJMBK-1.2K



TR-AMJMBK-1.5K

Trailer Frame Jacks

A-FRAME JACKS

PART #	LIFT CAP.	TRAVEL	R	E	DESCRIPTION	UNIT WT.	CASE QTY.	CASE WT.	REF. #
TR-JTW2K-14	2,000 lb.	14"	19"	33"	Drop Through Bolt-On or Weld-On, Black	7.70 lb.	220 pc.	1,738 lb.	TJA-2000-B
TR-JTW5K-15	5,000 lb.	15"	19"	34"	Drop Through Bolt-On or Weld-On, Black	10.17 lb.	220 pc.	2,237 lb.	TJA-5000-B



SWIVEL, WELD-ON JACKS

PART #	LIFT CAP.	TRAVEL	R	E	DESCRIPTION	UNIT WT.	CASE QTY.	CASE WT.	REF. #
TR-JTWR2K-10	2,000 lb.	10"	11"	21"	Top Wind Swivel, Retaining Ring Mount, Black	11.50 lb.	150 pc.	1,642 lb.	TJB-2001-B
TR-JTWR2K-15	2,000 lb.	15"	11"	26"	Top Wind Swivel, Retaining Ring Mount, Black	13.50 lb.	120 pc.	1,663 lb.	TJB-2002-B
TR-JSWR2K-10	2,000 lb.	10"	11"	21"	Side Wind Swivel, Retaining Ring Mount, Black	14.30 lb.	150 pc.	2,185 lb.	TJB-2001S-B
TR-JSWR2K-15	2,000 lb.	15"	11"	26"	Side Wind Swivel, Retaining Ring Mount, Black	16.50 lb.	120 pc.	2,025 lb.	TJB-2002S-B



SWIVEL, TUBE MOUNT JACKS

PART #	LIFT CAP.	TRAVEL	R	E	DESCRIPTION	UNIT WT.	CASE QTY.	CASE WT.	REF. #
TR-JTWT2K-10	2,000 lb.	10"	11"	21"	Top Wind Swivel, Tube Mount, Black	10.30 lb.	150 pc.	1,585 lb.	TJP-2001-B
TR-JTWT2K-15	2,000 lb.	15"	11"	26"	Top Wind Swivel, Tube Mount, Black	12.10 lb.	150 pc.	1,855 lb.	TJP-2002-B
TR-JTWT5K-10	5,000 lb.	10"	11"	21"	Top Wind Swivel, Tube Mount, Black	11.50 lb.	150 pc.	1,765 lb.	TJP-5001-B
TR-JTWT5K-15	5,000 lb.	15"	11"	26"	Top Wind Swivel, Tube Mount, Black	13.50 lb.	150 pc.	2,065 lb.	TJP-5002-B



DIRECT WELD, LIGHT-DUTY JACKS

PART #	LIFT CAP.	TRAVEL	R	E	DESCRIPTION	UNIT WT.	CASE QTY.	CASE WT.	REF. #
TR-JTWD7K-15	7,000 lb.	15"	22.50"	37.50"	Top Wind w/Drop-Leg, Square, Black	21.30 lb.	100 pc.	2,170 lb.	TJD-7000
TR-JSWD7K-15	7,000 lb.	15"	24.75"	39.75"	Side Wind w/Drop-Leg, Square, Black	23.30 lb.	100 pc.	2,370 lb.	TJD-7000-S



Trailer Frame Jacks

DIRECT WELD, MEDIUM-DUTY JACKS

PART #	LIFT CAP.	TRAVEL	R	E	DESCRIPTION	UNIT WT.	CASE QTY.	CASE WT.	REF. #
TR-JSWD12K-FP	12,000 lb.	12.50" - 26"	28.25"	41.75" - 54.25"	Side Wind w/Front Pull Pin, Crank Handle w/Spring Return, Square, Black	64 lb.	30 pc.	1,960 lb.	TJD-12000SP-F2
TR-JSWD12K-SP	12,000 lb.	12.50" - 26"	28.25"	41.75" - 54.25"	Side Wind w/Side Pull Pin, Crank Handle w/Spring Return, Square, Black	64 lb.	30 pc.	1,960 lb.	TJD-12000SP-R2



DIRECT WELD, TWO-SPEED MEDIUM-DUTY JACK

PART #	LIFT CAP.	TRAVEL	R	E	DESCRIPTION	UNIT WT.	CASE QTY.	CASE WT.	REF. #
TR-JSWD2S12K-FP	12,000 lb.	12.50" - 26"	29"	41.75" - 55"	Two Speed Side Wind w/ Front Pull Pin, Crank Handle w/Spring Return, Black	70 lb.	25 pc.	2,140 lb.	TJD2SP-12900SP-F



ELECTRIC JACK

PART #	LIFT CAP.	TRAVEL	R	E	DESCRIPTION	UNIT WT.	CASE QTY.	CASE WT.	REF. #
TR-JE3.5K-24	3,500 lb.	19.5"	9"	28.5"	12V DC Powered w/ Manual Override Crank Drop Through Bolt-On or Weld-On, Black	20.3 lb.	36 pc.	818 lb.	EJ-3520



SIDE WIND MARINE JACKS

PART #	LIFT CAP.	TRAVEL	R	E	DESCRIPTION	UNIT WT.	CASE QTY.	CASE WT.	REF. #
TR-JSWWM1K-10	1,000 lb.	10"	12.5"	22.50"	Side Wind Swivel, Weld-On, w/6" Caster	13.20 lb.	150 pc.	2,020 lb.	MJ-1000W
TR-JSWBM1.2K-10	1,200 lb.	11"	12.25"	23.25"	Side Wind Swivel, Bolt-On, w/6" Caster	14.70 lb.	120 pc.	1,801 lb.	MJ-1200B
TR-JSWBM1.5K-10	1,500 lb.	10"	13"	23"	Side Wind Swivel, Bolt-On, w/8" Caster	19.10 lb.	100 pc.	1,950 lb.	MJ-1500B
TTR-JSWBMD1.5K-10	1,500 lb.	10"	12"	22"	Side Wind Swivel, Bolt-On, w/6" Dual Caster	19.60 lb.	90 pc.	1,804 lb.	MJ-1500B-DWL
TR-JSWFBM2.5K-28	2,500 lb.	15"-28.5"	7.25"	22.25" - 35.75"	Square Side Wind Fixed, Bolt-On, w/ jack Ft	25.70 lb.	100 pc.	2,610 lb.	MJSQ-2500B

*Mounting plates are different and not interchangeable. Zinc Plated See Page 65 for replacement Marine Mounting Brackets

Cast-Head Couplers

A-FRAME



TR-CAC7K-2.00

PART #	BALL SIZE	TONGUE TYPE	SAE CLASS	CAPACITY	FINISH	UNIT WT.	CASE QTY.	CASE WT.	REF. #
TR-CAC7K-2.00	2"	A-Frame	4	7,000 lb.	Black	14 lb.	150 pc.	2,140 lb.	CA-5196-B
TR-CAC12.5K-2.31	2-5/16"	A-Frame	4	12,500 lb.	Black	18 lb.	125 pc.	2,290 lb.	CA-5296-B

ADJUSTABLE-SLEEVE LOCK



TR-AAZ7K-2.00

PART #	BALL SIZE	TONGUE TYPE	SAE CLASS	CAPACITY	FINISH	UNIT WT.	CASE QTY.	CASE WT.	REF. #
TR-CCA7K-2.00	2"	Adjustable	4	7,000 lb.	Black	11.20 lb.	175 pc.	2,000 lb.	CTA-196
TR-CCA12.5K-2.31	2-5/16"	Adjustable	4	12,500 lb.	Black	13.00 lb.	150 pc.	1,990 lb.	CTA-296

- With Grade 8 Bolts/Nuts

ADJUSTABLE-TOP LEVER LATCH



TR-CCA15K-2.31

PART #	BALL SIZE	TONGUE TYPE	SAE CLASS	CAPACITY	FINISH	UNIT WT.	CASE QTY.	CASE WT.	REF. #
TR-CCA15K-2.31	2-5/16"	Adjustable	4	15,000 lb.	Black	13.23 lb.	200 pc.	2,734 lb.	CTA-280

- With Grade 8 Bolts/Nuts

MOUNTING BRACKET



TR-ACMB-6

PART #	DESCRIPTION	CAPACITY	FINISH	UNIT WT.	CASE QTY.	CASE WT.	REF. #
TR-ACMB-6	Mounting Bracket, 6 Hole / 5 Position	15,000 lb.	Black	6.17 lb.	250 pc.	1,543 lb.	CTA-CB6

Stamped Couplers

STRAIGHT TONGUE



TR-CS2K-1.88X2.00



TR-CS2KZ-1.88X2.50

PART #	BALL SIZE	TONGUE SIZE	SAE CLASS	CAPACITY	FINISH	UNIT WT.	CASE QTY.	CASE WT.	REF. #
TR-CS2KZ-1.88X2.00	1-7/8"	2"	1	2,000 lb.	Zinc	2.50 lb.	500 pc.	1,290 lb.	CT-2001-Z
TR-CS2K-1.88X2.00	1-7/8"	2"	1	2,000 lb.	Oily	2.50 lb.	500 pc.	1,290 lb.	CT-2001-0
TR-CS2KZ-1.88X2.50	1-7/8"	2-1/2"	1	2,000 lb.	Zinc	2.60 lb.	500 pc.	1,340 lb.	CT-2002-Z
TR-CS2K-1.88X2.50	1-7/8"	2-1/2"	1	2,000 lb.	Oily	2.60 lb.	500 pc.	1,340 lb.	CT-2002-0
TR-CS2KZ-1.88X3.00	1-7/8"	3"	1	2,000 lb.	Zinc	3.02 lb.	500 pc.	1,550 lb.	CT-2003-Z
TR-CS2K-1.88X3.00	1-7/8"	3"	1	2,000 lb.	Oily	3.02 lb.	500 pc.	1,550 lb.	CT-2003-0
TR-CS3.5KZ-2.00X2.00	2"	2"	2	3,500 lb.	Zinc	4.10 lb.	500 pc.	2,090 lb.	CT-3001-Z
TR-CS3.5K-2.00X2.00	2"	2"	2	3,500 lb.	Oily	4.10 lb.	500 pc.	2,090 lb.	CT-3001-0
TR-CS3.5KZ-2.00X2.50	2"	2-1/2"	2	3,500 lb.	Zinc	4.20 lb.	500 pc.	2,140 lb.	CT-3002-Z
TR-CS3.5K-2.00X2.50	2"	2-1/2"	2	3,500 lb.	Oily	4.20 lb.	500 pc.	2,140 lb.	CT-3002-0
TR-CS3.5KZ-2.00X3.00	2"	3"	2	3,500 lb.	Zinc	4.40 lb.	500 pc.	2,240 lb.	CT-3003-Z
TR-CS3.5K-2.00X3.00	2"	3"	2	3,500 lb.	Oily	4.40 lb.	500 pc.	2,240 lb.	CT-3003-0
TR-CS5KZ-2.00X3.00	2"	3"	2	5,000 lb.	Zinc	5.20 lb.	500 pc.	2,640 lb.	CT-5003-Z
TR-CS5K-2.00X3.00	2"	3"	2	5,000 lb.	Oily	5.20 lb.	500 pc.	2,640 lb.	CT-5003-0



TR-CA5K-2.00



TR-CAY8K-2.00

A-FRAME & YOKE STYLE

PART #	BALL SIZE	TONGUE TYPE	SAE CLASS	CAPACITY	FINISH	UNIT WT.	CASE QTY.	CASE WT.	REF. #
TR-CA5K-2.00	2"	A-Frame	3	5,000 lb.	Black	6.50 lb.	250 pc.	1,665 lb.	CA-5100-B
TR-CAY8K-2.00	2"	A-Frame	4	8,000 lb.	Black	7.50 lb.	220 pc.	1,690 lb.	CA-5210-B
TR-CA14K-2.31	2-5/16"	A-Frame	4	14,000 lb.	Black	8.50 lb.	250 pc.	2,165 lb.	CA-5400-B

Gooseneck Couplers



TR-CGR25K-2.31



TR-CGS25K-2.31

ROUND & SQUARE GOOSENECK COUPLERS

PART #	BALL SIZE	DESCRIPTION	CAPACITY	UNIT WT.	CASE QTY.	CASE WT.	REF. #
TR-CGR25K-2.31	2-5/16"	Round Adjustable Gooseneck Coupler, 29" Retracted Height w/8" Travel, 4-1/2" Diameter Outer Tube, 4" Diameter Inner Tube w/Cast Locking Plate & 3/4" Load Bearing Pin, 2 Set Screws	25,000 lb.	54.73 lb.	30 pc.	1,642 lb.	GCPN-25008
TR-CGR30K-2.31	2-5/16"	Round Adjustable Gooseneck Coupler, 29" Retracted Height w/8" Travel, 4-1/2" Diameter Outer Tube, 4" Diameter Inner Tube w/Cast Locking Plate & 3/4" Load Bearing Pin, 2 Set Screws	30,000 lb.	61.36 lb.	30 pc.	1,841 lb.	GCPN-30008
TR-CGS25K-2.31	2-5/16"	Square Adjustable Gooseneck Coupler, 29" Retracted Height w/8" Travel, 4-1/2" Diameter Outer Tube, 4" Diameter Inner Tube w/Cast Locking Plate & 3/4" Load Bearing Pin, 1 Set Screw	25,000 lb.	70.16 lb.	30 pc.	2,105 lb.	GCSQ-25008

• All gooseneck couplers with load-bearing pin meet SAE J2638 standard

TOWING COMPONENTS



Winches

HAND WINCHES

PART #	DESCRIPTION	UNIT WT.	BOX QTY.	BOX WT	BOXES PER SKID	REF. #
TR-WH1K	Single-Speed Trailer Winch, 1,000 lb. Capacity, Zinc Plated	5.51 lb.	6 pc.	37 lb.	25 pc.	HW-1000
TR-WH1.4K	Single-Speed Trailer Winch, 1,400 lb. Capacity, Zinc Plated	5.86 lb.	6 pc.	40 lb.	25 pc.	HW-1400
TR-WH1.6K	Single-Speed Trailer Winch, 1,600 lb. Capacity, Zinc Plated	7.72 lb.	4 pc.	29 lb.	30 pc.	HW-1600
TR-WH2K	Two-Speed Trailer Winch, 2,000 lb. Capacity, Zinc Plated	8.27 lb.	4 pc.	35 lb.	30 pc.	HW-2000

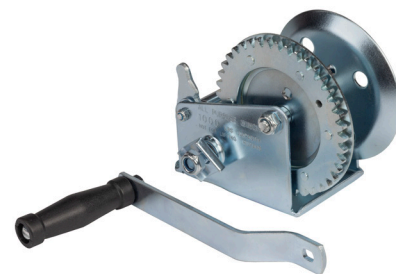

TR-WH1K

BRAKE WINCHES

PART #	DESCRIPTION	UNIT WT.	BOX QTY.	BOX WT	BOXES PER SKID	REF. #
TR-WB1K	Self-Activating Brake Winch, 1,000 lb. Capacity, Zinc Plated	5.51 lb.	6 pc.	37 lb.	25 pc.	BW-1000
TR-WB1.5K	Self-Activating Brake Winch, 1,500 lb. Capacity, Zinc Plated	7.50 lb.	6 pc.	50 lb.	25 pc.	BW-1400



TR-WB1K

WINCH STRAPS

PART #	DESCRIPTION	BOX QTY.	BOX WT.	BOXES PER SKID
TR-WH1KS	Nylon 2" x 26.2" Strap w/Snap Hook, 1,000 lb. Capacity	39 pc.	41 lb.	24
TR-WH1.4KS	Nylon 2" x 26.2" Strap w/Snap Hook, 1,400 lb. Capacity	36 pc.	37 lb.	24
TR-WH1.6KS	Nylon 2" x 26.2" Strap w/Snap Hook, 1,600 lb. Capacity	35 pc.	40 lb.	24
TR-WH2KS	Nylon 2" x 26.2" Strap w/Snap Hook, 2,000 lb. Capacity	35 pc.	44 lb.	24



TR-WH1KS

Trailer Jack Accessories & Parts

PART #	DESCRIPTION	UNIT WT.	CRATE QTY.	CRATE WT.	REF #
TR-AJF-2.00	Jack Foot w/hardware, 2" Tube, Zinc	1.20 lb.	1,000 pc.	1,200 lb.	JF-99
TR-AJFHD-2.00	Heavy-Duty Foot w/hardware, 2" Tube	1.90 lb.	1,000 pc.	1,780 lb.	JF-100-Z
TR-AJDL9.50-2.00	Drop Leg w/hardware, 9-1/2", 2" Tube	2.85 lb.	500 pc.	1,425 lb.	F-1005H-Z
TR-AJC-6.00	Removable 6" Caster Wheel, 2" Tube	4.76 lb.	300 pc.	1,428 lb.	JC-101
TR-AJBSP	Bottom Support Plate for A-Frame Jacks	0.69 lb.	3,000 pc.	2,079 lb.	JSP-100
TR-AMBR-P	Weld-On Retaining Mounting Bracket Plate	1.20 lb.	2,000 pc.	2,400 lb.	TJB-MB
TR-AMBR-R	Retaining Ring	0.02 lb.	2,500 pc.	50 lb.	SNP-RING
TR-AMBJT-2.00	Tubular Mounting Bracket, 2" Tube	1.00 lb.	2,000 pc.	2,000 lb.	TJP-IP
TR-AJCH12K	Crank Handle for 12,000 lb. Jack	2.98 lb.	500 pc.	1,490 lb.	TJD-12000-HD
TR-LE300600-24K	Lunette Eye w/ 5/8" Bolt and Nut, 24,000 lb.	11.68 lb.	180 pc.	2,142 lb.	C48660



JACK FOOT
TR-AJF-2.00



HEAVY-DUTY FOOT
TR-AJFHD-2.00



CRANK HANDLE
TR-AJCH12K



6" CASTER WHEEL
TR-AJC-6.00



LUNETTE EYE
TR-LE300600-24K



A-FRAME SUPPORT PLATE
TR-AJBSP



MOUNTING BRACKET PLATE
TR-AMBR-P



RETAINING RING
TR-AMBR-R



TUBULAR MOUNTING BRACKET
TR-AMBJT-2.00



DROP LEG
TR-AJDL9.50-2.00

TOWING COMPONENTS

Trailer Jack Accessories & Parts

PART #	DESCRIPTION	REF #
TR-AJHTW-2K	Replacement Jack Handle, 2,000 lb.	TJA-2000-HD
TR-AJHTW-5K	Replacement Jack Handle, 5,000 lb.	TJA-5000-HD
TR-AJHTW-7K	Replacement Jack Handle, Top Wind 7,000 lb. Drop Leg Jack	TJD-7000-HD
TR-AJHSW-7K	Replacement Jack Handle, Side Wind 7,000 lb. Drop Leg Jack	TJD-7000S-HD
TR-AJGK-12K	Replacement Gear Kit for 12,000 lb. Drop Leg Jack	TJD-12000-GR
TR-AMJHSW-1K	Replacement Marine Jack Handle for Side Wind, 1K	MJ-1000B-HD
TR-AMJHSW-1.2K	Replacement Marine Jack Handle for Side Wind, 1.2K	MJ-1200B-HD
TR-AMJHSW-1.5K	Replacement Marine Jack Handle for Side Wind, 1.5K	MJ-1500B-HD
TR-AMJMBK-1K	Replacement Marine Jack Mounting Bracket Kit, 1K	MJ-1000B-MK
TR-AMJMBK-1.2K	Replacement Marine Jack Mounting Bracket Kit, 1.2K	MJ-1200B-MK
TR-AMJMBK-1.5K	Replacement Marine Jack Mounting Bracket Kit, 1.5K	MJ-1500B-MK
TR-CRK1.88-2K	Coupler Repair Kit, 1-3/4" Ball, 2,000 lb.	CT-2000-RK
TR-CRK2.00-3.5K	Coupler Repair Kit, 2" Ball, 3,500 lb.	CT-3000-RK
TR-CRK2.00-5K	Coupler Repair Kit, 2" Ball, 5,000 lb.	CT-5100-RK



**JACK HANDLE,
TOP WIND**

TR-AJHTW-2K
TR-AJHTW-5K



**JACK HANDLE,
TOP WIND**

TR-AJHTW-7K



**JACK HANDLE,
SIDE WIND**

TR-AJHSW-7K



**MARINE JACK
HANDLE,
SIDE WIND**

TR-AMJHSW-1K
TR-AMJHSW-1.2K
TR-AMJHSW-1.5K

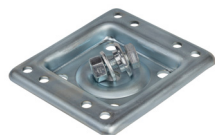

TR-AMJMBK-1K

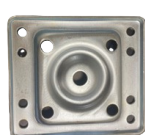

TR-AMJMBK-1.2K



TR-AMJMBK-1.5K

MARINE JACK MOUNTING BRACKET KITS

TR-AMJMBK-1K
TR-AMJMBK-1.2K
TR-AMJMBK-1.5K



**COUPLER
REPAIR KIT**

TR-CRK2.00-3.5K



**GEAR KIT FOR
12K DROP
LEG JACK**

TR-AJGK-12K

PACKAGED PARTS KITS



PACKAGED PARTS

SUPPLYING THE WORLD



REACH OUT TO YOUR ACCOUNT EXECUTIVE FOR DISPLAY PURCHASE INFORMATION

BEARING & RACE KITS

EACH KIT CONTAINS:	PART #	DESCRIPTION
INNER/OUTER BEARINGS & RACES, GREASE SEAL, COTTER PIN & TANG WASHER	PP-BGK-1	2K Bearing Kit, w/ 1.250" Seal ID
	PP-BGK-2	2.5K Bearing Kit, w/ 1.500" Seal ID
	PP-BGK-3	3.5K Bearing Kit, w/ 1.719" Seal ID
	PP-BGK-4	5.2K Bearing Kit, w/ 2.125" Seal ID
	PP-BGK-5	5.2K Bearing Kit, w/ 2.25" Seal ID
	PP-BGK-6	6K Bearing Kit, w/ 2.125" Seal ID
	PP-BGK-7	6K Bearing Kit, w/ 2.25" Seal ID
	PP-BGK-8	7K Bearing Kit, w/ 2.125" Seal ID
	PP-BGK-9	7K Bearing Kit, w/ 2.25" Seal ID
	PP-BGK-10	8K Bearing Kit, w/ 2.25" Seal ID
	PP-BGK-11	10K Bearing Kit, w/ 2.25" Seal ID
	PP-BGK-12	12K-16K Bearing Kit, w/ 2.25" Seal ID



GREASE SEAL KITS

EACH KIT CONTAINS:	PART #	DESCRIPTION
(2) GREASE SEALS	PP-GSK-1	2K Grease Seal Kit w/ 1.250" Seal ID
	PP-GSK-2	2.5K Grease Seal Kit w/ 1.500" Seal ID
	PP-GSK-3	3.5K Grease Seal Kit w/ 1.719" Seal ID
	PP-GSK-4	5.2K-7K Grease Seal Kit w/ 2.125" Seal ID
	PP-GSK-5	5.2K-7K Grease Seal Kit w/ 2.250" Seal ID



OIL SEAL KITS

EACH KIT CONTAINS:	PART #	DESCRIPTION
(2) OIL SEALS	PP-OSK-1	8K Unitized Oil Seal Kit, w/ 2.250" ID X 3.372" OD x 0.490"
	PP-OSK-2	10K Unitized Oil Seal Kit, w/ 2.875" ID X 3.875" OD x 0.515"
	PP-OSK-3	12/16K Unitized Oil Seal Kit, w/ 3.125" ID X 4.500" OD x 0.600"



DUST CAP KITS

EACH KIT CONTAINS:	EACH LUBED KIT CONTAINS:	PART #	DESCRIPTION
(2) DUST CAPS	(2) DUST CAPS, (2) RUBBER PLUGS	PP-DC-1	2K-3.5K Dust Cap Kit, w/ 1.999" OD
		PP-DC-2	5.2K-6K Dust Cap Kit, w/ 2.450" OD
		PP-DC-3	7K-8K Dust Cap Kit, w/ 2.720" OD
		PP-DC-4	2K-3.5K Dust Cap Kit, w/ 1.999" OD, Lubed
		PP-DC-5	5.2K-6K Dust Cap Kit, w/ 2.450" OD, Lubed
		PP-DC-6	7K-8K Dust Cap Kit, w/ 2.720" OD, Lubed
		PP-DC-7	Rubber Plugs Dust Cap Kit



OIL CAP KITS - TRURYDE DEFENDER

EACH KIT CONTAINS:	PART #	DESCRIPTION
(2) TRURYDE DEFENDER CAPS WITH O-RING, CENTER PLUG AND SET SCREW	PP-DC-11	8K Oil Cap 2 7/8" Thread, DC-O-288
	PP-DC-12	8K Grease Cap 2 7/8" Thread, DC-G-288
	PP-DC-13	10K-16K Oil Cap 4" Thread, DC-O-400
	PP-DC-14	10K-16K Grease Cap 4" Thread, DC-G-400



U-BOLT & TIE PLATE KITS

EACH KIT CONTAINS:

(2) TIE PLATES,
(4) U-BOLTS
& (8) NUTS



PART #	DESCRIPTION
PP-UBTPK-1	U-Bolt Kit, 1.75" Spring 1-3/4" Tube
PP-UBTPK-2	U-Bolt Kit, 1.75" Spring 2-3/8" Tube, 5-1/2"
PP-UBTPK-3	U-Bolt Kit, 1.75" Spring 2-3/8" Tube, 6-1/4"
PP-UBTPK-4	U-Bolt Kit, 2" Spring 2-3/8" Tube, 5-1/2"
PP-UBTPK-5	U-Bolt Kit, 2" Spring 2-3/8" Tube, 6-1/4"
PP-UBTPK-6	U-Bolt Kit, 1.75" Spring 3" Tube, 6-1/2"
PP-UBTPK-7	U-Bolt Kit, 1.75" Spring 3" Tube, 7"
PP-UBTPK-8	U-Bolt Kit, 2" Spring 3" Tube, 6-1/2"
PP-UBTPK-9	U-Bolt Kit, 2" Spring 3" Tube, 7"

U-BOLT & NUT KITS

EACH KIT CONTAINS:

(2) U-BOLTS & (4) FLANGE
SERRATED HEX NUTS



PART #	DESCRIPTION
PP-UBK-1	U-Bolt & Nut Kit, 1-3/4" x 4.29", Round 3/8"-24 THD
PP-UBK-2	U-Bolt & Nut Kit, 2.38" x 5-1/2", Round 1/2"-20 THD
PP-UBK-3	U-Bolt & Nut Kit, 2.38" x 6-1/4", Round 1/2"-20 THD
PP-UBK-4	U-Bolt & Nut Kit, 3" x 6-1/2", Round 1/2"-20 THD
PP-UBK-5	U-Bolt & Nut Kit, 3" x 7", Round 1/2"-20 THD

SHACKLE BOLT KITS

EACH KIT CONTAINS:

(4) SHACKLE BOLTS
& (4) TOP LOCK
HEX NUTS



PART #	DESCRIPTION
PP-SBK-1	Shackle Bolt Kit, 3" x 9/16"-18 THD
PP-SBK-2	Shackle Bolt Kit, 3-1/2" x 9/16"-18 THD
PP-SBK-3	Shackle Bolt Kit, 3" x 7/16"-20 THD
PP-SBK-4	Shackle Bolt Kit, 3-1/2" x 7/16"-20 THD
PP-SBK-5	Shackle Bolt Kit, 4-3/4" x 7/8"-9 THD

SHACKLE LINK KITS







EACH KIT CONTAINS:

(4) SHACKLE LINKS



PART #	DESCRIPTION
PP-SLK-1	Shackle Link Kit, 225
PP-SLK-2	Shackle Link Kit, 256
PP-SLK-3	Shackle Link Kit, 313

SPINDLE NUT KITS

EACH KIT CONTAINS:	PART #	DESCRIPTION
FOR 1 SPINDLE (ITEMS IN DESCRIPTION)	PP-SNK-1	Spindle Nut Kit, Nut, Washer and Cotter Pin
	PP-SNK-2	Spindle Nut Kit, Lube, Nut, D-Washer and Tang Washer
	PP-SNK-3	Spindle Nut Kit, 2 FA-TW100, 1" Tang Washers
	PP-SNK-4	Spindle Nut Kit, 10K Nut, Washer and Cotter Pin
	PP-SNK-5	Spindle Nut Kit, 12-16K, Nut, Washer and Cotter Pin
		
FA-SN100 FA-SW100 FA-DW100 FA-TW100 FA-CP175		

LUG NUT KITS

EACH KIT CONTAINS:	PART #	DESCRIPTION
1/2" = (6) LUG NUTS	PP-WNK-1	Lug Nut Kit, FA-6-080, Lug Nut 60° 1/2"-20
9/16" = (8) LUG NUTS	PP-WNK-2	Lug Nut Kit, FA-6-053, Lug Nut 60° 9/16"-18
5/8" = (8) LUG NUTS	PP-WNK-3	Lug Nut Kit, FA-6109, Lug Nut 90° 5/8"-18
		

WHEEL STUD KITS

EACH KIT CONTAINS:	PART #	DESCRIPTION
(4) WHEEL STUDS	PP-WSK-1	Wheel Stud, 1/2" - 20 x 2"
*1/2" CONTAINS (6) WHEEL STUDS	PP-WSK-2	Wheel Stud, 9/16" - 18 x 2.31"
	PP-WSK-3	Wheel Stud, 5/8" - 18 x 2.75", 0.689 KNURL DIA
	PP-WSK-4	Wheel Stud, 9/16"-18 X 2.30", 0.689 KNURL DIA
	PP-WSK-5	Wheel Stud, 5/8"-18 X 3.44" 0.689 KNURL DIA
	PP-WSK-6	Wheel Stud, BOLT - M22 X 1.5" X 4.79", GR 10.9, Zinc

BUSHING KITS

EACH KIT CONTAINS:	PART #	DESCRIPTION
(8) BUSHINGS	PP-BUK-1	Spring Eye Bushing Kit, 1-3/4" x 9/16" ID
	PP-BUK-2	Spring Eye Bushing Kit, 2" x 9/16" ID
		

IDLER HUB KITS

EACH KIT CONTAINS:

HUB, INNER/OUTER BEARINGS,
GREASE SEAL, LUG NUTS,
DUST CAP, RUBBER PLUG
*FOR 1 WHEEL



PART #	DESCRIPTION
PP-RVIK-1	2.5K Idler Hub Kit, 4400
PP-RVIK-2	2.5K Idler Hub Kit, 5450
PP-RVIK-3	3.5K Idler Hub Kit, 5450
PP-RVIK-4	3.5K Idler Hub Kit, 5475
PP-RVIK-5	3.5K Idler Hub Kit, 5500
PP-RVIK-6	3.5K Idler Hub Kit, 5550
PP-RVIK-7	3.5K Idler Hub Kit, 6550
PP-RVIK-8	6K Idler Hub Kit, 655
PP-RVIK-9	7K Idler Hub Kit, 865
PP-RVIK-10	7K Idler Hub Kit, 865 - 9/16" Studs
PP-RVIK-11	2K Idler Hub Kit, 4400 (for BT8)
PP-RVIK-12	2K Idler Hub Kit, 5450 (for BT8)

PRE-GREASED
ADD **-PG** TO END OF PART NUMBER FOR
PRE-GREASED HUBS OR DRUMS

BRAKE DRUM KITS

EACH KIT CONTAINS:

DRUM, INNER/OUTER BEARINGS,
GREASE SEAL, LUG NUTS,
DUST CAP, RUBBER PLUG,

*8K KITS
INCLUDE GREASE CAP

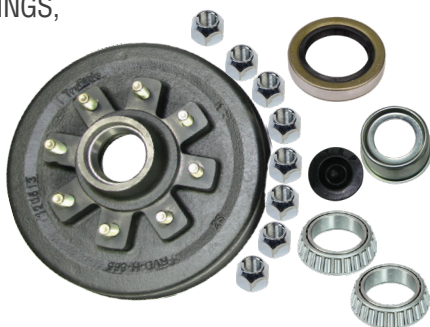

PART #	DESCRIPTION
PP-RVDK-1	2K Brake Drum Kit, 5450
PP-RVDK-2	3.5K Brake Drum Kit, 5450
PP-RVDK-3	3.5K Brake Drum Kit, 5475
PP-RVDK-4	3.5K Brake Drum Kit, 5500
PP-RVDK-5	3.5K Brake Drum Kit, 5550
PP-RVDK-6	3.5K Brake Drum Kit, 6550
PP-RVDK-7	6K Brake Drum Kit, 655
PP-RVDK-8	7K Brake Drum Kit, 865
PP-RVDK-9	7K Brake Drum Kit, 865 9/16" Studs
PP-RVDK-10	8K Brake Drum Kit, Hybrid RVD-8KHYP-865-580-THD
PP-RVDK-11	8K Brake Drum Kit, Hybrid RVD-8KHYP-865-916-THD
PP-RVDK-12	8K Brake Drum Kit, RVD-8K-865DUAL-580-THD

PRE-GREASED
ADD **-PG** TO END OF PART NUMBER FOR
PRE-GREASED HUBS OR DRUMS

BRAKE ASSEMBLY KITS

EACH KIT CONTAINS:

2K-10K - 1 BRAKE ASSEMBLY



PP-BKK-21/22 - 8K

1 Brake Assembly
4 Bolts, Washers & Nuts

PP-BKK-23/24 - 10K

1 Brake Assembly
7 Bolts, Washers & Nuts

PART #	DESCRIPTION
PP-BKK-1	10" Electric Brake Left Hand
PP-BKK-2	10" Electric Brake Right Hand
PP-BKK-3	10" Electric Brake Left Hand, Self-Adjust
PP-BKK-4	10" Electric Brake Right Hand, Self-Adjust
PP-BKK-5	12" Electric Brake Left Hand
PP-BKK-6	12" Electric Brake Right Hand
PP-BKK-7	12" Electric Brake Left Hand, Self-Adjust
PP-BKK-8	12" Electric Brake Right Hand, Self-Adjust
PP-BKK-9	10" Hydraulic Uni-Servo Right Hand
PP-BKK-10	10" Hydraulic Uni-Servo Left Hand
PP-BKK-11	10" Hydraulic Uni-Servo Free-Backing Right Hand
PP-BKK-12	10" Hydraulic Uni-Servo Free-Backing Left Hand
PP-BKK-13	10" Hydraulic Uni-Servo Free-Backing Dacromet Finish Right Hand
PP-BKK-14	10" Hydraulic Uni-Servo Free-Backing Dacromet Finish Left Hand
PP-BKK-15	12" Hydraulic Uni-Servo Right Hand
PP-BKK-16	12" Hydraulic Uni-Servo Left Hand
PP-BKK-17	12" Hydraulic Uni-Servo Free-Backing Right Hand
PP-BKK-18	12" Hydraulic Uni-Servo Free-Backing Left Hand
PP-BKK-19	12" Hydraulic Uni-Servo Free-Backing Dacromet Finish Right Hand
PP-BKK-20	12" Hydraulic Uni-Servo Free-Backing Dacromet Finish Left Hand
PP-BKK-21	8K Electric Brake, 4 Hole 12-1/4"X3-3/8" Left Hand
PP-BKK-22	8K Electric Brake, 4 Hole 12-1/4"X3-3/8" Right Hand
PP-BKK-23	10K Electric Self Adj Brake, 12-1/4"X3-3/8" Left Hand
PP-BKK-24	10K Electric Self Adj Brake, 12-1/4"X3-3/8" Right Hand

BRAKE PART KITS

EACH KIT CONTAINS:



BK-10/12E-ADJKIT



10" Magnet Kit



12" Magnet Kit



10K Magnet Kit



10" Shoe/Lining Kit



12" Shoe/Lining Kit









BK-WHLCYL-01

PART #	DESCRIPTION
PP-BKP-1	Adjuster w/ Spring Kit 10/12" Electric Brakes, BK-10/12E-ADJKIT
PP-BKP-2	10" Electric Brake Magnet, Spring and Clip
PP-BKP-3	12" Electric Brake Magnet, Spring and Clip
PP-BKP-4	10K Electric Brake Magnet, Spring and Clip
PP-BKP-5	10" Primary and Secondary Shoe/Lining, Hold Down Pins, Springs and Clips
PP-BKP-6	12" Primary and Secondary Shoe/Lining, Hold Down Pins, Springs and Clips
PP-BKP-7	10"/12" Brake Adjuster Wheel Cylinder Kit, Left and Right w/ attaching parts
PP-BKP-8	10"/12" Wheel Cylinder, Left
PP-BKP-9	10"/12" Wheel Cylinder, Right

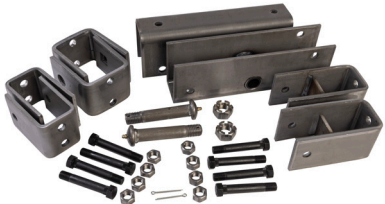



PACKAGED PARTS

TANDEM AXLE HANGER KITS





EACH KIT CONTAINS:	PART #	DESCRIPTION
<p>(2) HG-15844-F (2) HG-15864-C (2) HG-15854-R (2) EQ-1344-C</p> <p>W/ ATTACHING NUTS, BOLTS AND COTTER PINS</p>	 <p>PP-EQK-03</p>	<p>Tandem Axle Hanger Kit - Fits 2" Slipper Spring w/ 4" Hangers</p>
<p>(2) HG-2891-F (2) HG-2951-C (2) HG-3061-R (2) EQ-1304-C</p> <p>W/ ATTACHING NUTS, BOLTS AND COTTER PINS</p>	 <p>PP-EQK-04</p>	<p>Tandem Axle Hanger Kit - Fits 2" Slipper Springs using 1304 Style EQ and 3"-Wide Tall Hangers</p>
<p>(2) HG-15843-F (2) HG-15863-C (2) HG-15853-R (2) EQ-4541</p> <p>W/ ATTACHING NUTS, BOLTS AND COTTER PINS</p>	 <p>PP-EQK-05 PP-EQK-06</p>	<p>Tandem Axle Hanger Kit - Fits 2" Slipper Springs using 4541 EQ and 3" Hangers</p> <p>PP-EQK-05 with WET BOLTS PP-EQK-06 with DRY BOLTS</p>
<p>(2) HG-2942-C (2) EQ-13140</p> <p>W/ ATTACHING NUTS AND BOLTS</p>	 <p>PP-EQK-07</p>	<p>Tandem Axle Hanger Kit - Fits 2.5" Spring using 10K Short, E-Coated Equalizer</p>
<p>(2) HG-2942-C (2) EQ-13141</p> <p>W/ ATTACHING NUTS AND BOLTS</p>	 <p>PP-EQK-08</p>	<p>Tandem Axle Hanger Kit - Fits 2.5" Spring using 10K Long, E-Coated Equalizer</p>
<p>(2) HG-2493-C (2) EQ-13108</p> <p>W/ ATTACHING NUTS AND BOLTS</p>	 <p>PP-EQK-09</p>	<p>Tandem Axle Hanger Kit - Fits 3.0" Spring using 10K Medium, E-Coated Equalizer</p>

PACKAGED PARTS

TANDEM AXLE HANGER KITS



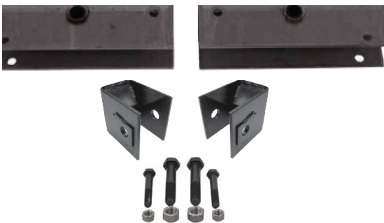

EACH KIT CONTAINS:	PART #	DESCRIPTION
(2) HG-2493-C (2) EQ-13109 W/ ATTACHING NUTS AND BOLTS	 PP-EQK-10	Tandem Axle Hanger Kit - Fits 3.0" Spring using 10K Long, E-Coated Equalizer
(2) HG-281-F (2) HG-291-C (2) HG-3028-R (2) EQ-1344-C W/ ATTACHING NUTS, BOLTS AND COTTER PINS	 PP-EQK-11	Tandem Axle Hanger Kit - Fits 2" Slipper Springs using 1344 EQ & 3"-Wide Tall Hangers
(2) HG-281-F (2) HG-291-C (2) HG-3028-R (2) EQ-1304-C W/ ATTACHING NUTS, BOLTS AND COTTER PINS	 PP-EQK-12	Tandem Axle Hanger Kit - Fits 2" Slipper Springs using 1304 EQ & 3"-Wide Tall Hangers
(2) HG-15844-F (2) HG-15864-C (2) HG-15854-R (2) EQ-4541 W/ ATTACHING NUTS, BOLTS AND COTTER PINS	 PP-EQK-13	Tandem Axle Hanger Kit - Fits 2" Slipper Springs using 4541 EQ and 4" Wide Hangers
(4) HG-144 (2) HG-246 (8) SL-263 (2) EQ-E1 W/ ATTACHING NUTS AND BOLTS	 PP-EQK-14	Tandem Axle Hanger Kit - Fits 1-3/4" Slipper Spring
(6) HG-325 (8) SL-263 (2) EQ-E1 W/ ATTACHING NUTS AND BOLTS	 PP-EQK-15	Tandem Axle Hanger Kit - Fits 1-3/4" Slipper Spring

TANDEM AXLE HANGER KITS



EACH KIT CONTAINS:	PART #	DESCRIPTION
<p>(4) HG-144 (2) HG-325 (8) SL-263 (2) EQ-E1</p> <p>W/ ATTACHING NUTS AND BOLTS</p>	 <p>PP-EQK-16</p>	<p>Tandem Axle Hanger Kit - Fits 1-3/4" Slipper Spring</p>
<p>(6) HG-325 (8) SL-313 (2) EQ-E1</p> <p>W/ ATTACHING NUTS AND BOLTS</p>	 <p>PP-EQK-17</p>	<p>Tandem Axle Hanger Kit - Fits 1-3/4" Slipper Spring</p>
<p>(4) HG-144 (2) HG-325 (8) SL-313 (2) EQ-E1</p> <p>W/ ATTACHING NUTS AND BOLTS</p>	 <p>PP-EQK-18</p>	<p>Tandem Axle Hanger Kit - Fits 1-3/4" Slipper Spring</p>
<p>(6) HG-325 (8) SL-225 (2) EQ-E1</p> <p>W/ ATTACHING NUTS AND BOLTS</p>	 <p>PP-EQK-19</p>	<p>Tandem Axle Hanger Kit - Fits 1-3/4" Slipper Spring</p>
<p>(2) HG-2951-C (2) EQ-1344-C</p> <p>W/ ATTACHING NUTS, BOLTS AND COTTER PINS</p>	 <p>PP-EQK-20</p>	<p>Attaching Parts Kit for 36" Tandem Axle Spacing - Fits 2" Slipper Springs</p>

PACKAGED PARTS

TANDEM AXLE HANGER KITS

EACH KIT CONTAINS:	PART #	DESCRIPTION
<p>(2) HG-2951-C (2) EQ-1304-C</p> <p>W/ ATTACHING NUTS, BOLTS AND COTTER PINS</p>	 <p>PP-EQK-21</p>	<p>Attaching Parts Kit for 33.5" Tandem Axle Spacing - Fits 2" Slipper Springs</p>
<p>(2) HG-281-F (2) HG-291-C (2) HG-3028-R (2) EQ-5541</p> <p>W/ ATTACHING NUTS, BOLTS AND COTTER PINS</p>	 <p>PP-EQK-22</p>	<p>Tandem Axle Hanger Kit. Fits 2" Slipper Spring 3" Wide Hangers & 5541 Equalizer</p>
<p>(4) HG-200 (2) HG-325 (8) SL-313 (2) EQ-E1</p> <p>W/ ATTACHING NUTS AND BOLTS</p>	 <p>PP-EQK-23</p>	<p>Tandem Axle Hanger Kit - Fits 1-3/4" Slipper Spring</p>
<p>(2) HG-15844-F (2) HG-15864-C (2) HG-15854-R (2) EQ-5541</p> <p>W/ ATTACHING NUTS, BOLTS AND COTTER PINS</p>	 <p>PP-EQK-24</p>	<p>Tandem Axle Hanger Kit - Fits 2" Slipper Spring 4" Wide Hangers & 5541 Equalizer</p>
<p>(6) HG-246 (8) SL-263 (2) EQ-E1</p> <p>W/ ATTACHING NUTS AND BOLTS</p>	 <p>PP-EQK-25</p>	<p>Tandem Axle Hanger Kit - Fits 1-3/4" Double Eye Spring</p>

SINGLE AXLE HANGER KITS

EACH KIT CONTAINS:	PART #	DESCRIPTION
(2) HG-2874-F (2) HG-PS-HR31W W/ ATTACHING NUTS AND BOLTS	 PP-HRK-01	Single Axle Hanger Kit, - Fits 2.5" Slipper Spring
(2) HG-2867-F (2) HG-3066-R W/ ATTACHING NUTS AND BOLTS	 PP-HRK-02	Single Axle Hanger Kit, - Fits 3" Slipper Spring
(2) HG-144 (2) HG-PS-HR47R (4) SL-313 W/ ATTACHING NUTS AND BOLTS	 PP-HRK-03	Single Axle Hanger Kit - Fits 1.75" Double-Eye Spring
(2) HG-144 (2) HG-112 (4) SL-263 W/ ATTACHING NUTS AND BOLTS	 PP-HRK-04	Single Axle Hanger Kit - Fits 1.75" Double-Eye Spring
(2) HG-144 (2) HG-112 (4) SL-313 W/ ATTACHING NUTS AND BOLTS	 PP-HRK-05	Single Axle Hanger Kit - Fits 1.75" Double-Eye Spring
(2) HG-325 (2) HG-112 (4) SL-313 W/ ATTACHING NUTS AND BOLTS	 PP-HRK-06	Single Axle Hanger Kit - Fits 1.75" Double-Eye Spring
(2) HG-325 (2) HG-PS-HR47R (4) SL-313 W/ ATTACHING NUTS AND BOLTS	 PP-HRK-07	Single Axle Hanger Kit - Fits 1.75" Double-Eye Spring
(2) HG-200 (2) HG-PS-HR47R (4) SL-313 W/ ATTACHING NUTS AND BOLTS	 PP-HRK-08	Single Axle Hanger Kit - Fits 1.75" Double-Eye Spring

PACKAGED PARTS

Reach out to your Account Executive for more information about Marketing & Promotional materials available.

Counter Mats



Vinyl Banners



Co-branded Sales Flyers

MARKETING MATERIALS

Axle Component Diagram – 2,000 lb. Capacity

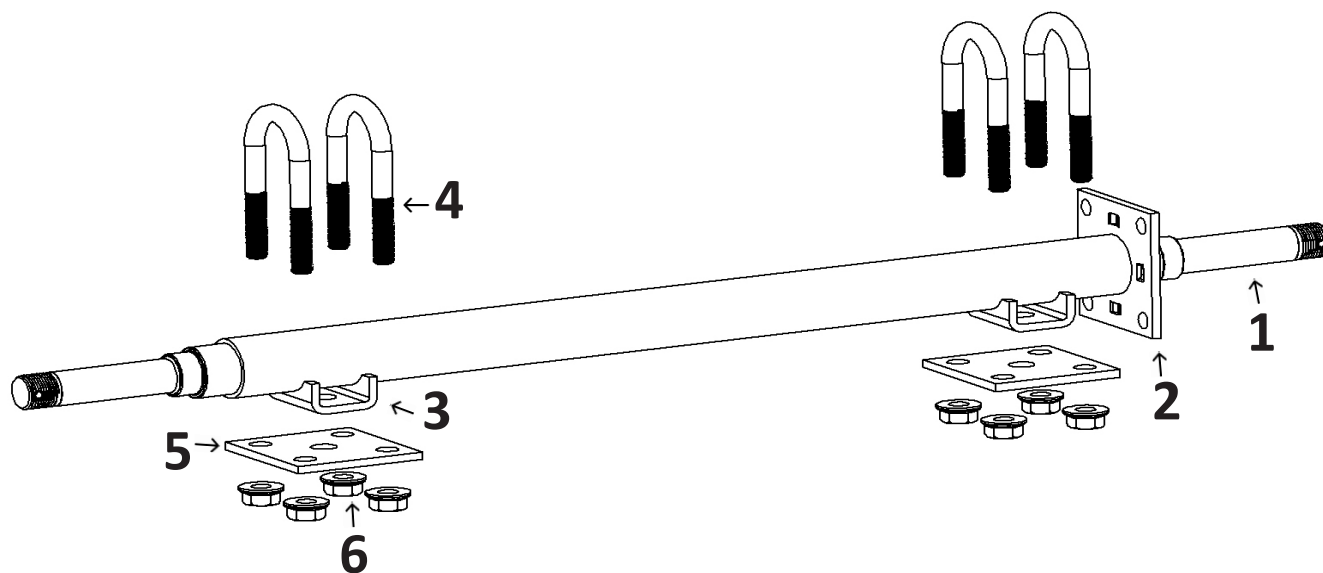

ITEM	PART #	DESCRIPTION	CATALOG PAGE
1	SP-HF-BT8	Bar Stock, Butt Weld Style Spindle	10-12
1	SP-HF-BT8L	Bar Stock, Butt Weld Style Spindle	10-12
1	SP-125BT8	Round Bar Stock, 1.25" Diameter Spindle	10-12
1	SP-150BT8	Round Bar Stock, 1.50" Diameter Spindle	10-12
1	SP-150BT8-SQ	Square Bar Stock, 1.50" Diameter Spindle	10-12
2	PFL-41.30	Brake Flange	13
2	PFL-41.51	Brake Flange	13
3	SS-175	Spring Seat, for 1.75" OD Axle Tube	41
4	UBR-175429-38C	U-Bolt 3/8"-16 Thread	40
4	UBR-175429-38F	U-Bolt 3/8"-24 Thread	40
4	UBR-175429-50F	U-Bolt 1/2"-20 Thread	40
5	TP-175173	Tie Plate	38-39
5	TP-175175	Tie Plate	38-39
6	FA-FLN375	Nut, Lock, Zinc	50-51

Hub Component Diagram – 2,000 lb. Capacity

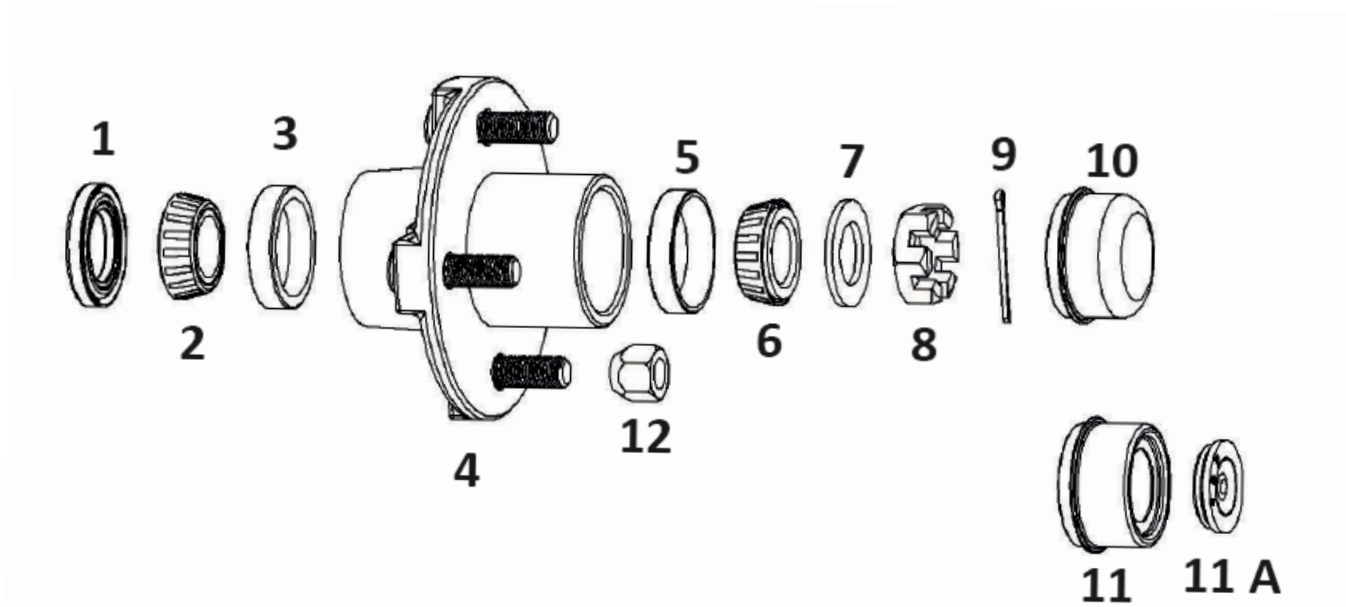

ITEM	PART #	DESCRIPTION	CATALOG PAGE
1	GS-1250DLR	Grease Seal, Double Lip Rubber Coated, 1.250"	18
1	GS-1250SL	Grease Seal, Single Lip, 1.250"	18
1	GS-1250DL	Grease Seal, Double Lip, 1.250"	18
2	L-44643	Inner Bearing, Cone	16-17
3	L-44610	Inner Bearing, Cup	16-17
4	RVI-BT-4400	Idler Hub, 440 BT	24
5	L-44610	Outer Bearing, Cup	16-17
6	L-44643	Outer Bearing, Cone	16-17
7	FA-TW100	Spindle Washer, Tang	14
7	FA-SW100	Spindle Washer, Flat Round	14
7	FA-DW-100	Spindle Washer, Flat D-Washer	14
8	FA-SN100	Spindle Nut, 6 Slot	14
9	FA-CP175	Cotter Pin	14
10	DC-200	Dust Cap	20
11	DC-200L	Dust Cap, Lubed	20
11A	DC-RP	Rubber Plug For Lubed Dust Cap Hole	20
12	FA-6-080	Wheel Nut, Cone	50-51

Axle Component Diagram – 2,500 lb. Capacity

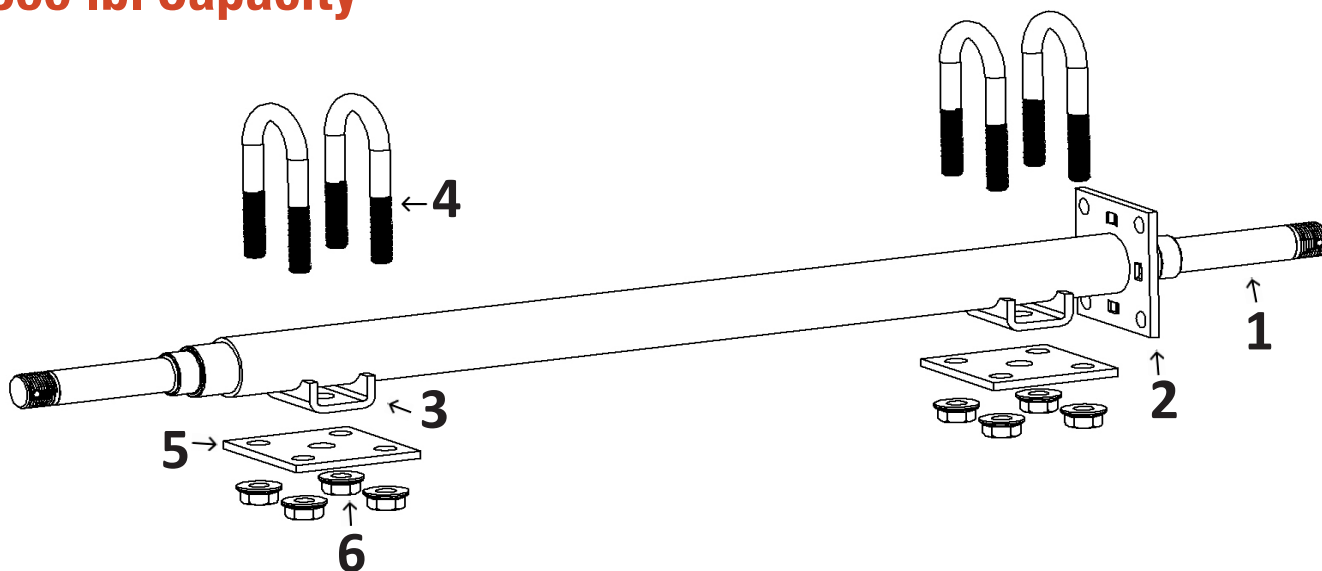

ITEM	PART #	DESCRIPTION	CATALOG PAGE
1	SP-HF-84BT16	Bar Stock, Butt Weld Style Spindle	10-12
1	SP-HF-BT16	Bar Stock, Butt Weld Style Spindle	10-12
1	SP-HF-BT16L	Bar Stock, Butt Weld Style Spindle	10-12
1	SP-125BT16	Round Bar Stock, 1.25" Diameter Spindle	10-12
1	SP-150BT16L	Round Bar Stock, 1.50" Diameter Spindle	10-12
1	SP-150BT16-SQ	Square Bar Stock, 1.50" Diameter Spindle	10-12
2	PFL-41.30	Brake Flange	13
2	PFL-41.51	Brake Flange	13
4	SS-175	Spring Seat, for 1.75" OD Axle Tube	41
4	UBR-175429-38C	U-Bolt 3/8"-16 Thread	40
4	UBR-175429-38F	U-Bolt 3/8"-24 Thread	40
5	UBR-175429-50F	U-Bolt 1/2"-20 Thread	40
5	TP-175173	Tie Plate	38-39
5	TP-175175	Tie Plate	38-39
6	FA-FLN375	Nut, Lock, Zinc	50-51

Hub Component Diagram – 2,500 lb. Capacity

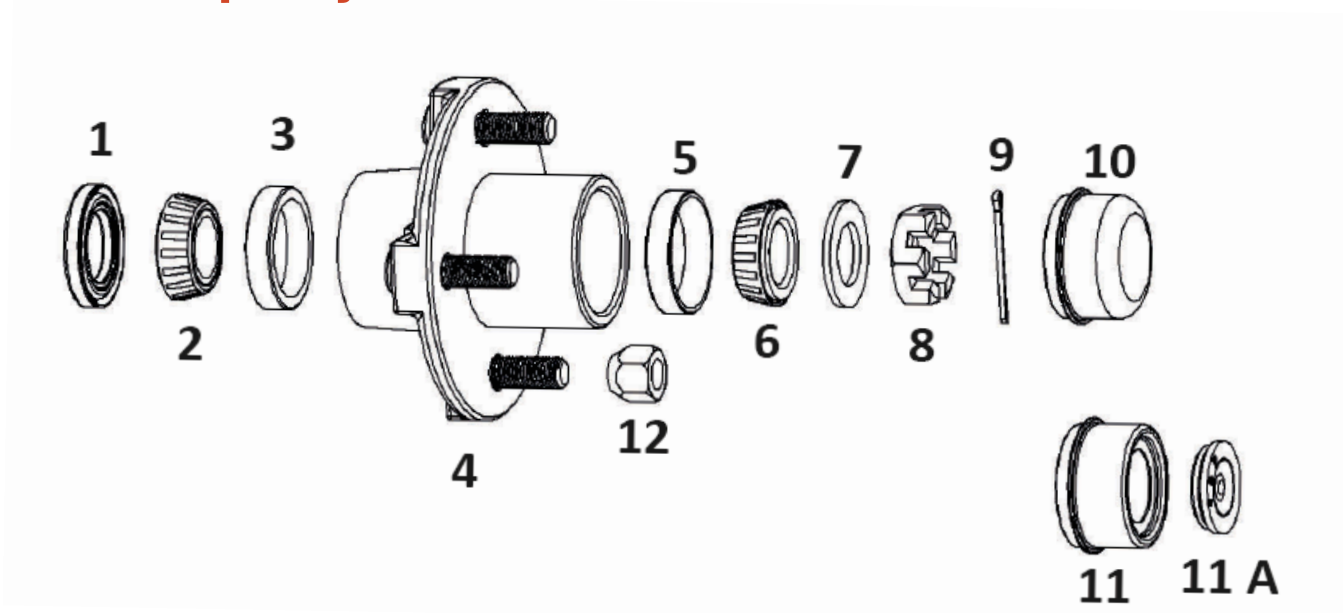

ITEM	PART #	DESCRIPTION	CATALOG PAGE
1	GS-1500DLR	Grease Seal, Double Lip Rubber Coated, 1.500"	18
1	GS-1500SL	Grease Seal, Single Lip, 1.500"	18
1	GS-1500DL	Grease Seal, Double Lip, 1.500"	18
2	L-44649	Inner Bearing, Cone	16-17
3	L-44610	Inner Bearing, Cup	16-17
4	RVI-BT-5450	Idler Hub, 545 BT	24
5	L-44610	Outer Bearing, Cup	16-17
6	L-44649	Outer Bearing, Cone	16-17
7	FA-TW100	Spindle Washer, Tang	14
7	FA-SW100	Spindle Washer, Flat Round	14
7	FA-DW-100	Spindle Washer, Flat D-Washer	14
8	FA-SN100	Spindle Nut, 6 Slot	14
9	FA-CP175	Cotter Pin	14
10	DC-200	Dust Cap	20
11	DC-200L	Dust Cap, Lubed	20
11A	DC-RP	Rubber Plug For Lubed Dust Cap Hole	20
12	FA-6-080	Wheel Nut, Cone	50-51

AXLE & HUB COMPONENT DIAGRAMS

Axle Component Diagram – 3,500 lb. Capacity

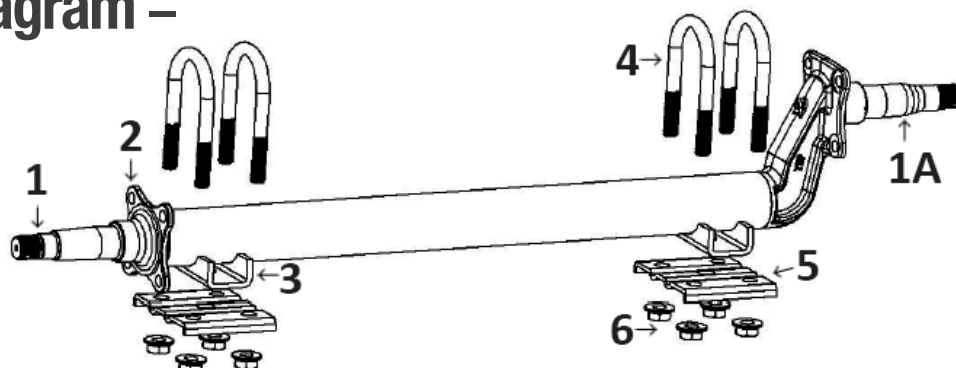

ITEM	PART #	DESCRIPTION	CATALOG PAGE
1	SP-HF-IF-84L	Butt Weld Style, Integrated Flange Spindle	10-12
1	SP-HF-IF-8455	Butt Weld Style, Integrated Flange Spindle	10-12
1	SP-HF-84L	Butt Weld Style, Hot Forged Spindle	10-12
1	SP-HF-84S	Butt Weld Style, Hot Forged Spindle	10-12
1	SP-HF-8455	Butt Weld Style, Hot Forged Spindle	10-12
1	SP-17584	Round Bar Stock Spindle	10-12
1	SP-20084	Round Bar Stock Spindle	10-12
1	SP-20484-SQ	Square Bar Stock Spindle	10-12
1	SP-35684-SQ	Square Bar Stock Spindle	10-12
1A	SP-TT-175F	Hot Forged 4" Drop, Flanged Spindle	10-12
1A	SP-TT-175AF	Hot Forged 4" Drop, Flanged Spindle	10-12
2	PFL-41.75	Brake Flange	13
2	PFL-42.27	Brake Flange	13
3	SS-238	Spring Seat, for 2.38" OD Axle Tube	41
3	SS-300	Spring Seat, for 3.00" OD Axle Tube	41
4	UBR-238513-44F	U-Bolt, 7/16"-20 Thread	40
4	UBR-238550-50F	U-Bolt, 1/2"-20 Thread	40
4	UBR-238625-50F	U-Bolt, 1/2"-20 Thread	40
4	UBR-300650-50F	U-Bolt, 1/2"-20 Thread	40
5	TP-238175	Tie Plate	38-39
5	TP-238200	Tie Plate	38-39
5	TP-300175	Tie Plate	38-39
5	TP-300200	Tie Plate	38-39
5	TP-238175-50R	Tie Plate	38-39
5	TP-238175-R	Tie Plate	38-39
5	TP-238200R	Tie Plate	38-39
5	TP-300175R	Tie Plate	38-39
6	FA-FLN375	Nut, Lock, Zinc	50-51
6	FA-6-92Z	Nut, Flange, Zinc	50-51

Hub Component Diagram – 3,500 lb. Capacity

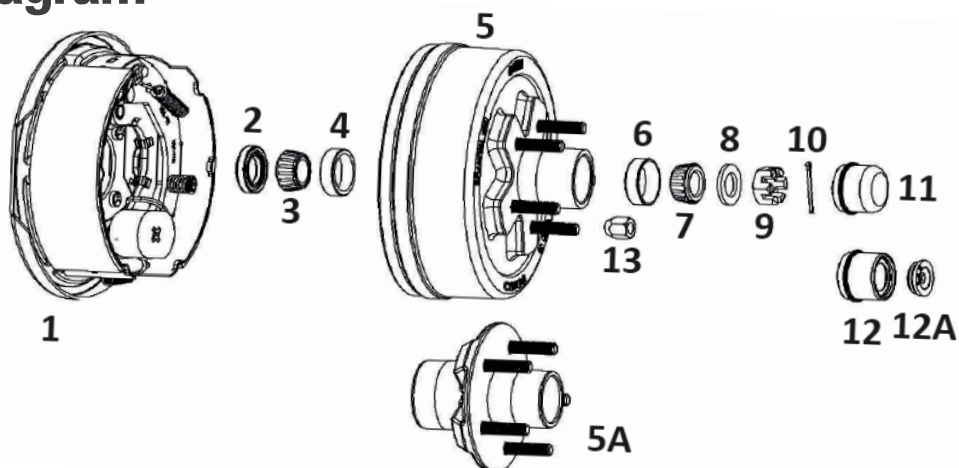

ITEM	PART #	DESCRIPTION	CATALOG PAGE
1	BK-10E-01/ BK-10E-02	10"x 2.25" LH/RH Brake Assembly	26
1	BK-10E-01SA/BK-10E-02SA	10"x 2.25" LH/RH Self-Adjusting Brake Assembly	26
2	GS-1719DL	Grease Seal, Double Lip, 1.720"	18
2	GS-1719SL	Grease Seal, Single Lip, 1.720"	18
2	GS-1719DLR	Grease Seal, Double Lip Rubber Coated, 1.720"	18
3	L-68149	Inner Bearing, Cone	16-17
4	L-68111	Inner Bearing, Cup	16-17
5	RVD-U-5450	Brake Drum, 5 Bolt on 4.50" BC	22
5	RVD-U-5475	Brake Drum, 5 Bolt on 4.75" BC	22
5	RVD-U-5500	Brake Drum, 5 Bolt on 5.00" BC	22
5	RVD-U-5550	Brake Drum, 5 Bolt on 5.50" BC	22
5	RVD-U-6550	Brake Drum, 6 Bolt on 5.50" BC	22
5A	RVI-U-5450	Idler Hub, 5 Bolt on 4.50" BC	24
5A	RVI-U-5475	Idler Hub, 5 Bolt on 4.75" BC	24
5A	RVI-U-5500	Idler Hub, 5 Bolt on 5.00" BC	24
5A	RVI-U-5550	Idler Hub, 5 Bolt on 5.50" BC	24
5A	RVI-U-6550	Idler Hub, 6 Bolt on 5.50" BC	24
6	L-44610	Outer Bearing, Cup	16-17
7	L-44649	Outer Bearing, Cone	16-17
8	FA-SW100	Spindle Washer, Flat Round	14
8	FA-DW100	9 Spindle Nut, 6 Slot	14
8	FA-TW100	Spindle Washer, Tang	14
9	FA-SN100	Spindle Washer, Flat D-Washer	14
10	FA-CP175	Cotter Pin	14
11	DC-200	Dust Cap	20
12	DC-200L	Dust Cap, Lubed	20
12A	DC-RP	Rubber Plug For Lubed Dust Cap Hole	20
13	FA-6-080	Wheel Nut, Cone	50-51

Axle Component Diagram – 5,200-6,000 lb. Capacity

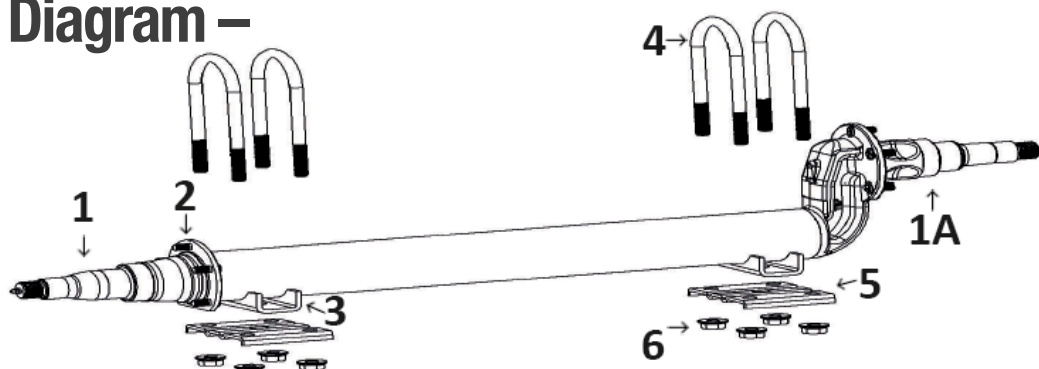

ITEM	PART #	DESCRIPTION	CATALOG PAGE
1	SP-HF-IFB-42L	Butt Weld Style, Integrated Flange Spindle	10-12
1	SP-HF-42L	Butt Weld Style, No Flange Spindle	10-12
1	SP-22542	Round Bar Stock Spindle	10-12
1	SP-50642-SQ	Square Bar Stock Spindle	10-12
1A	SP-UT-IFB-300	Hot Forged 4" Drop, Integrated Flange Spindle	10-12
2	PFL-52.31	Brake Flange	13
2	PFL-52.75	Brake Flange	13
2	PFL-53.12	Brake Flange	13
2	PFL-52.31-31	Brake Flange	13
2	PFL-52.53	Brake Flange	13
2	PFL-52.53-31	Brake Flange	13
3	SS-300	Spring Seat, for 3.00" OD Axle Tube	41
4	UBR-300650-50F	U-Bolt, 1/2" - 20 Thread	40
4	UBR-300700-50F	U-Bolt, 1/2" - 20 Thread	40
4	UBR-300700-56F	U-Bolt, 9/16" - 18 Thread	40
5	TP-300175	Tie Plate	38-39
5	TP-300200	Tie Plate	38-39
5	TP-300209	Tie Plate	38-39
5	TP-350200	Tie Plate	38-39
5	TP-300175R	Tie Plate	38-39
5	TP-300200-56R	Tie Plate	38-39
6	FA-FLN375	Nut, Lock, Zinc	50-51
6	FA-6-92Z	Nut, Flange, Zinc	50-51

Hub Component Diagram – 5,200-6,000 lb. Capacity

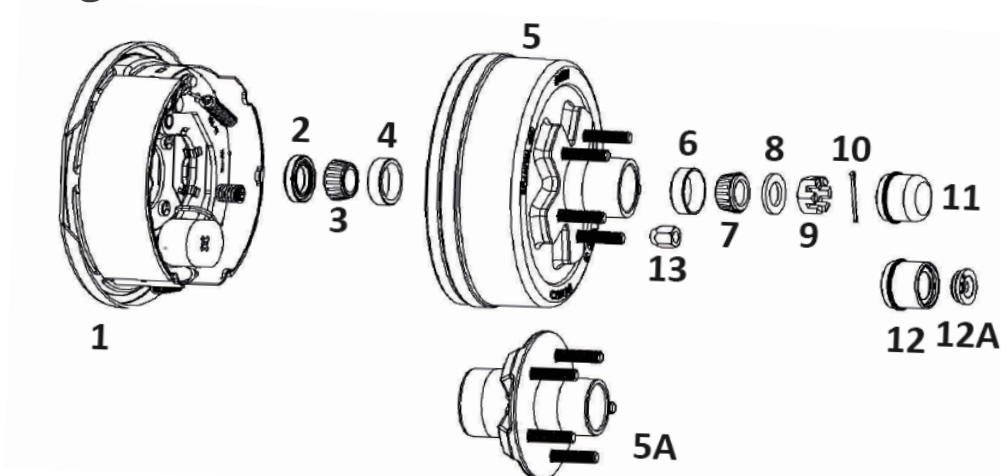

ITEM	PART #	DESCRIPTION	CATALOG PAGE
1	BK-12E-01/BK-12E-02	12" x 2" LH/RH Brake Assembly	26
1	BK-12E-01SA/BK-12E-02SA	12" x 2" LH/RH Self-Adjusting Brake Assembly	26
2	GS-2125DL	Grease Seal, Double Lip, 2.125"	18
2	GS-2250DL	Grease Seal, Double Lip, 2.250"	18
3	25580	Inner Bearing, Cone	16-17
4	25520	Inner Bearing, Cup	16-17
5	RVD-H-655	Brake Drum, 6 Bolt on 5.50" BC	22
5A	RVI-H-655	Idler Hub, 6 Bolt on 6.50" BC	24
6	15245	Outer Bearing, Cup	16-17
7	15123	Outer Bearing, Cone	16-17
8	FA-SW100	Spindle Washer, Flat Round	14
8	FA-DW100	Spindle Washer, Flat D-Washer	14
8	FA-TW100	Spindle Washer, Tang	14
9	FA-SN100	Spindle Nut, 6 Slot	14
10	FA-CP175	Cotter Pin	14
11	DC-250	Dust Cap	20
12	DC-250L	Dust Cap, Lubed	20
12A	DC-RP	Rubber Plug For Lubed Dust Cap Hole	20
13	FA-6-080	Wheel Nut, Cone	50-51

Axle Component Diagram – 7,000 lb. Capacity

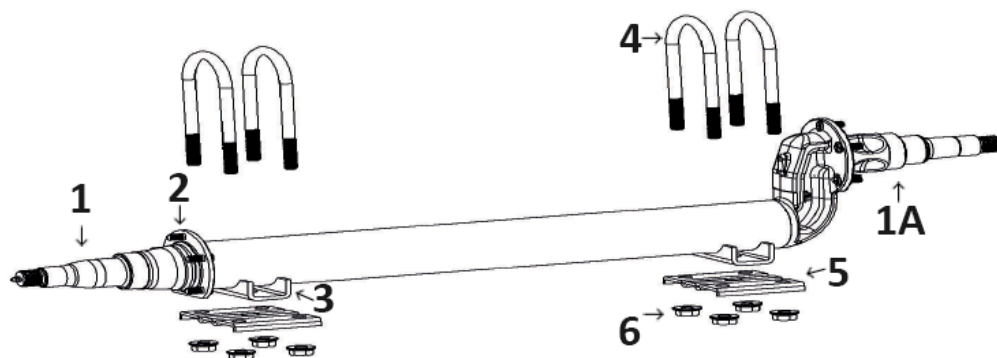

ITEM	PART #	DESCRIPTION	CATALOG PAGE
1	SP-HF-IFB-42L	Butt Weld Style, Integrated Flange Spindle	10-12
1	SP-HF-42L	Butt Weld Style, No Flange Spindle	10-12
1	SP-22542	Round Bar Stock Spindle	10-12
1	SP-50642-SQ	Square Bar Stock Spindle	10-12
1A	SP-UT-IFB-300	Hot Forged 4" Drop, Integrated Flange Spindle	10-12
2	PFL-52.31	Brake Flange, Welded	13
2	PFL-52.75	Brake Flange, Welded	13
2	PFL-53.12	Brake Flange, Welded	13
2	PFL-52.31-31	Brake Flange, Welded	13
2	PFL-52.53	Brake Flange, Welded	13
2	PFL-52.53-31	Brake Flange, Welded	13
3	SS-300	Spring Seat, for 3.00" OD Axle Tube	41
4	UBR-300650-50F	U-Bolt, 1/2" - 20 Thread	40
4	UBR-300700-50F	U-Bolt, 1/2" - 20 Thread	40
4	UBR-300700-56F	U-Bolt, 9/16" -18 Thread	40
5	TP-300175	Tie Plate	38-39
5	TP-300200	Tie Plate	38-39
5	TP-300209	Tie Plate	38-39
5	TP-350200	Tie Plate	38-39
5	TP-300175R	Tie Plate	38-39
5	TP-300200-56R	Tie Plate	38-39
6	FA-FLN375	Nut, Lock, Zinc	50-51
6	FA-6-92Z	Nut, Flange, Zinc	50-51

Hub Component Diagram – 7,000 lb. Capacity

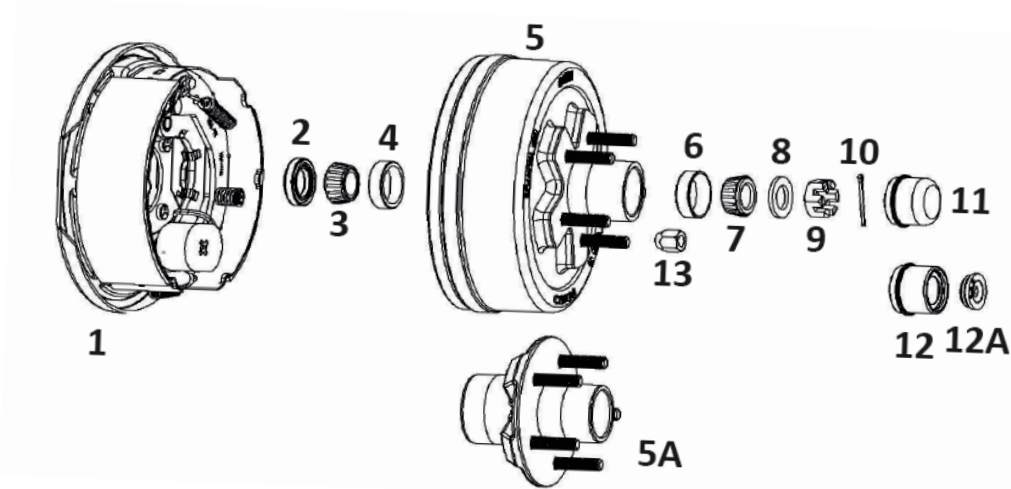

ITEM	PART #	DESCRIPTION	CATALOG PAGE
1	BK-12E-01/BK-12E-02	12" x 2" LH/RH Brake Assembly	26
1	BK-12E-01SA/BK-12E-02SA	12" x 2" LH/RH Self-Adjusting Brake Assembly	26
2	GS-2125DL	Grease Seal, Double Lip, 2.125"	18
2	GS-2250DL	Grease Seal, Double Lip, 2.250"	18
3	25580	Inner Bearing, Cone	16-18
4	25520	Inner Bearing, Cup	16-18
5	RVD-H-865	Brake Drum, 8 Bolt on 6.50" BC	22
5	RVD-H-865-916	Brake Drum, 8 Bolt on 6.50" BC, 9/16" Studs	22
5A	RVI-H-865	Idler Hub, 8 Bolt on 6.50" BC	24
5A	RVI-H-865-916	Idler Hub, 8 Bolt on 6.50" BC, 9/16" Studs	24
6	14276	Outer Bearing, Cup	16-17
7	14125A	Outer Bearing, Cone	16-17
8	FA-SW100	Spindle Washer, Flat Round	14
8	FA-DW100	Spindle Washer, Flat D-Washer	14
8	FA-TW100	Spindle Washer, Tang	14
9	FA-SN100	Spindle Nut, 6 Slot	14
10	FA-CP175	Cotter Pin	14
11	DC-275	Dust Cap	20
12	DC-275L	Dust Cap, Lubed	20
12A	DC-RP	Rubber Plug For Lubed Dust Cap Hole	20
13	FA-6-080	Wheel Nut, Cone, 1/2-20 60 Degree	50-51
13	FA-6-053	Wheel Nut, Cone, 9/16-18 60 Degree	50-51

Hub Component Diagram – 8,000 lb. Capacity (Hybrid)

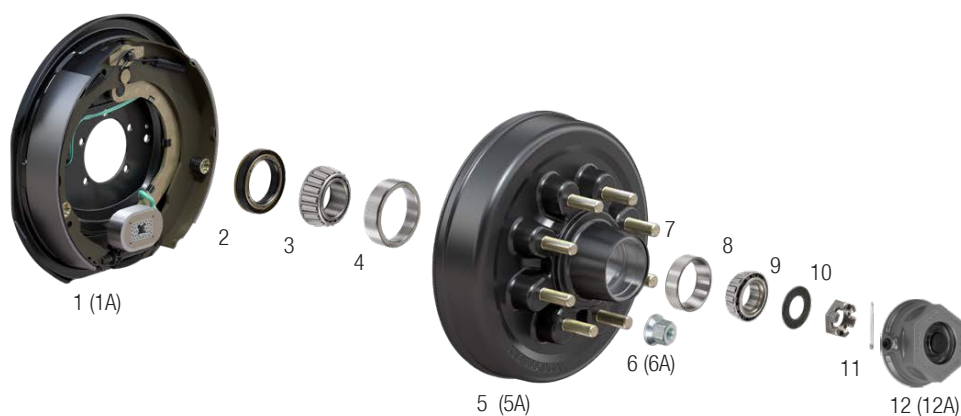

ITEM	PART #	DESCRIPTION	CATALOG PAGE
1	BK-12E-01/BK-12E-02	12" x 2" LH/RH Brake Assembly	26-31
1A	BK-12E-01SA/BK-12E-02SA	12" x 2" LH/RH Self-Adjusting Brake Assembly	26-31
2	OS-2250UNI	Unitized oil seal (2.25" ID)	19
3	25580	Inner Bearing, Cone	16-17
4	25520	Inner Bearing, Cup	16-17
5	RVD-8KHYB-865-580	Brake Drum, 8 Bolt on 6 1/2", 5/8" Studs	23
5A	RVD-8KHYB-865-916	Brake Drum, 8 Bolt on 6 1/2", 9/16" Studs	23
6	FA-6-058	Lug Nut 60° (5/8"-18)	50-51
6A	FA-6-053	Lug Nut 60° (9/16"-18)	50-51
7	02420	Outer Bearing, Cup	16-17
8	02475	Outer Bearing, Cone	16-17
9	FA-SW100	Spindle Washer, Flat Round	14
10	FA-SN100	Spindle Nut, 6 Slot	14
11	FA-CP175	Cotter Pin	14
12	DC-G-288	Grease Cap	20
12A	DC-O-288	Oil Cap	20

Hub Component Diagram – 8,000 lb. Capacity

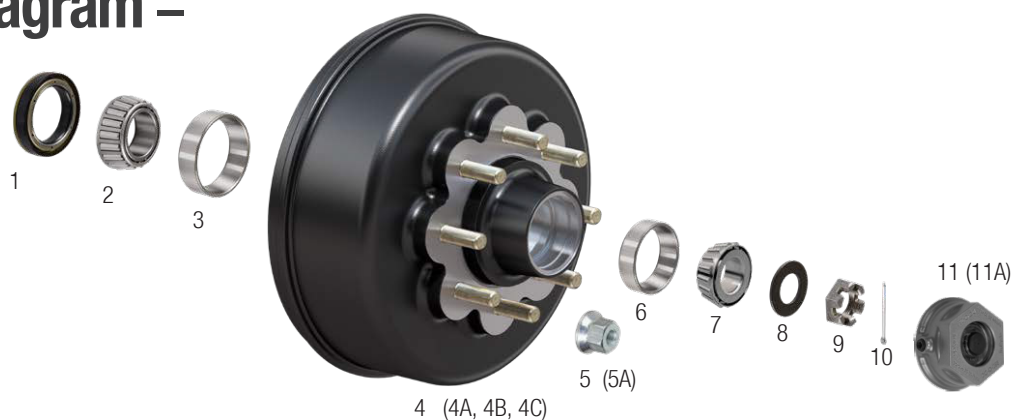

ITEM	PART #	DESCRIPTION	CATALOG PAGE
Not shown	BK-8KE-02	Electric Brake Assembly, Right (12-1/4" x 3-3/8")	26-31
Not shown	BK-8KE-01	Electric Brake Assembly, Left (12-1/4" x 3-3/8")	26-31
1	OS-2250UNI	Unitized oil seal (2..25" ID)	19
2	25580	Inner Bearing, Cone (25580)	16-17
3	25520	Inner Bearing, Cup (25520)	16-17
4	RVD-8K-865-580	Hub Drum with 5/8" studs (8 on 6-1/2") OIL	23
4A	RVD-8K-865-916	Hub Drum with 9/16" studs (8 on 6-1/2") OIL	23
4B	RVD-8K-865-580-G	Hub Drum with 5/8" studs (8 on 6-1/2") GREASE	23
4C	RVD-8K-865-916-G	Hub Drum with 9/16" studs (8 on 6-1/2") GREASE	23
4-IH-A	RVI-8K-865-580	Idler Hub Only - 865-5/8" Studs, Threaded	23
4-IH-B	RVI-8K-865-916	Idler Hub Only - 865-9/16" Studs, Threaded	23
4-FAS	FA-183536	Brake Drum to Idler Hub assembly fastener 1/2"-13x1.50" with hex head flange	
5	FA-6-058	Lug Nut (60° (5/8"-18)	50-51
5A	FA-6-053	Lug Nut 60° (9/16"-18)	50-51
6	02420	Outer Bearing, Cup	16-17
7	02475	Outer Bearing, Cone	16-17
8	FA-SW100	Spindle Washer, Flat Round	14
9	FA-SN100	Spindle Nut, 6 Slot	14
10	FA-CP175	Cotter Pin	14
11	DC-G-288	Grease Cap	20
11A	DC-O-288	Oil Cap	20

Hub Component Diagram – 10,000 lb. Capacity

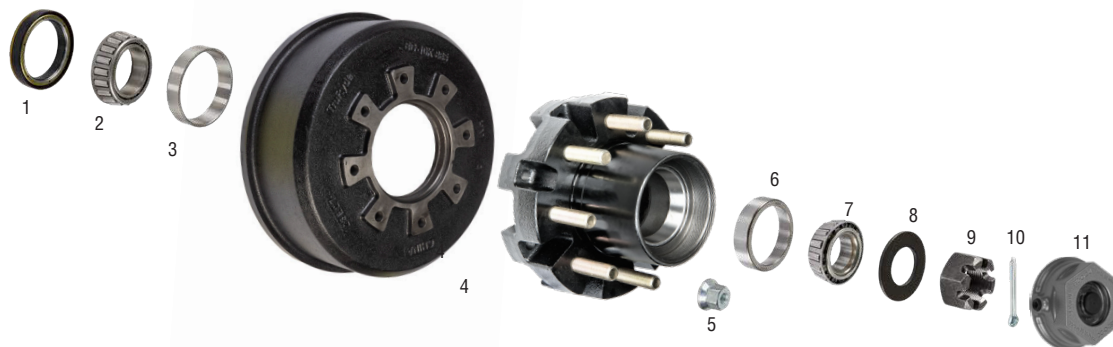

ITEM	PART #	DESCRIPTION	CATALOG PAGE
Not shown	BK-10KE-01/02	10K Self Adj Brake Assembly, 12-1/4" x 3-3/8" LH/RH	26-31
Not shown	BK-10KH-01/02	10K Hydraulic Brake Assembly, 12-1/4" x 3-3/8", 7 Bolt, LH/RH	26-31
1	OS-2875UNI	Unitized oil seal (2.875" ID)	19
2	387A	Inner Bearing, Cone	16-17
3	382A	Inner Bearing, Cup	16-17
4	RVD-10K-865-580	Brake Hub/Drum, 8 Bolt on 6 1/2", 5/8" Studs	23
4-D	BD-10K-865	Brake Drum Only, 865-10K	23
4-IH	RVI-10K-865-580	Idler Hub Only - 8 Bolt on 6 1/2", 5/8" Studs	23
4-FAS	FA-183536	Brake Drum to Idler Hub assembly fastener 1/2"-13x1.50" with hex head flange	
5	FA-6-058	Lug nut 60° (5/8"-18)	50-51
6	25520	Outer Bearing, Cup	16-17
7	25580	Outer Bearing, Cone	16-17
8	FA-SW150	Spindle Washer, Flat Round	14
9	FA-SN150	Spindle Nut, 6 Slot	14
10	FA-CP175	Cotter Pin	14
11	DC-G-400	Grease Cap	20
11A	DC-O-400	Oil Cap	20

Hub Component Diagram – 10,000 lb. Capacity (Short)



ITEM	PART #	DESCRIPTION	CATALOG PAGE
Not shown	BK-10KE-01/02	10K Self Adj Brake Assembly, 12-1/4" x 3-3/8" LH/RH	26-31
Not shown	BK-10KH-01/02	10K Hydraulic Brake Assembly, 12-1/4" x 3-3/8", 7 Bolt, LH/RH	26-31
1	OS-2875UNI	Unitized oil seal (2.875" ID)	19
2	387A	Inner Bearing, Cone	16-17
3	382A	Inner Bearing, Cup	16-17
4	RVD-10KSHT-865-580	Short Brake Hub/Drum, 8 Bolt on 6 1/2", 5/8" Studs	23
4-D	BD-10K-SHT-865	Brake Drum Only - 865-10K SHORT	23
4-IH	RVI-10KSHT-865-580	Idler Hub Only - 8 Bolt on 6 1/2", 5/8" Studs	23
4-FAS	FA-183536	Brake Drum to Idler Hub assembly fastener 1/2"-13x1.50" with hex head flange	
5	FA-6-058	Lug Nut 60° (5/8"-18)	50-51
6	25520	Outer Bearing, Cup	16-17
7	25580	Outer Bearing, Cone	16-17
8	FA-SW150	Spindle Washer, Flat Round	14
9	FA-SN150	Spindle Nut, 6 Slot	14
10	FA-CP175	Cotter Pin	14
11	DC-G-400	Grease Cap	20
11A	DC-O-400	Oil Cap	20

Hub Component Diagram – 12,000 lb. Capacity



ITEM	PART #	DESCRIPTION	CATALOG PAGE
Not shown	BK-12KE-01/02	12K/16K Electric, 12-1/4" x 5", Self-Adjusting, 7 Hole	26-31
Not shown	BK-12KH-01/02	12K/16K Hydraulic, 12-1/4" x 5", 7 Hole	26-31
1	OS-3125UNI	Unitized oil seal (3.125" ID)	19
2	3984	Inner Bearing, Cone	17
3	3920	Inner Bearing, Cup	17
4	RVD-12K-865-580	Brake Hub/Drum, 8 Bolt on 6 1/2", 5/8" studs, oil	23
4-D	BD-12K/16K-865	Brake Drum Only -12-1/4"X5"-12/16K	23
4-IH	RVI-12K-865-580	Idler Hub Only - 865-5/8-12K	23
4-FAS	FA-183536	Brake Drum to Idler Hub assembly fastener 1/2"-13x1.50" with hex head flange	
5	FA-6-058	Lug Nut 60° (5/8"-18)	50-51
6	28622	Outer Bearing, Cup	17
7	28682	Outer Bearing, Cone	17
8	FA-SW175	Spindle Washer, Flat Round	14
9	FA-SN175	Spindle Nut, 6 Slot	14
10	FA-CP175	Cotter Pin	14
11	DC-G-400	Grease Cap	20
11A	DC-O-400	Oil Cap	20

Hub Component Diagram – 16,000 lb. Capacity



ITEM	PART #	DESCRIPTION	CATALOG PAGE
Not shown	BK-12KE-01/02	12K/16K, 12-1/4" x 5", Self-Adjusting, 7 Hole	26-31
1	OS-3125UNI	Unitized oil seal (3.125" ID)	19
2	3984	Inner Bearing, Cone	17
3	3920	Inner Bearing, Cup	17
4	RVD-16K-8275-M22	Brake Hub/Drum, 8 Bolt on 2.75mm, M22 Studs	23
4-D	BD-12K/16K-865	Brake Drum Only-12-1/4"X5"-12/16K	23
4-IH	RVI-16K-8275-M22	Idler Hub Only - 8 ON 275MM - 16K	23
4-FAS	FA-183536	Brake Drum to Idler Hub assembly fastener 1/2"-13x1.50" with hex head flange	
5	FA-WN-M22-1530	Wheel Nut M22-1.5" X 30 MM	50-51
6	28622	Outer Bearing, Cup	17
7	28682	Outer Bearing, Cone	17
8	FA-SW175	Spindle Washer, Flat Round	14
9	FA-SN175	Spindle Nut	14
10	FA-CP175	Cotter Pin	14
11	DC-G-400	Grease Cap	20
11A	DC-O-400	Oil Cap	20

Secondary Custom Operations

TRP International offers numerous secondary custom operations as well as custom manufactured components through our subsidiary company and global supplier partners.

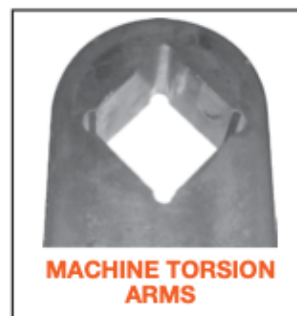

Custom Manufactured Components



Terms & Conditions

TERMS

All orders are subject to credit approval by our credit department. Net 30 days from date of shipment, unless specified otherwise in writing by TRP International. All past due accounts shall accrue interest at a rate of 1.5% per month based upon the outstanding balance at the end of the month plus any additional fees incurred in the collection process, including attorney fees.

PRICES

All shipments will be at the prices in effect at order acceptance, including any possible raw material surcharges that may be implemented. Prices and specifications are subject to change without notice. Minimum order of \$100.00 is required. Any order less than \$100.00 will be subject to a \$25.00 handling charge.

PROCESSING

ACCOUNTS THAT PAY WITHIN TERMS MAY SHIP PREPAY & ADD TO INVOICE IN ORDER TO RECEIVE OUR LTL CARRIER DISCOUNTED FREIGHT RATES.

ORDERS

TRP International's acceptance of customer orders, whether verbal or written does not include an acknowledgment or acceptance on behalf of TRP of any terms or conditions of customers purchase order, whether stated expressly or implied.

CANCELLATION AND CHANGES

Due to immediate production of manufactured products, orders containing these items are considered firm and are not subject to cancellation or change without approval. Any approved cancellations or changes are subject to additional charges at TRP International's discretion.

FREIGHT

All shipments are F.O.B. TRP International and are shipped "Freight Collect" unless specified otherwise in writing by TRP. Products are carefully inspected and packed to assure that they will arrive in good condition.

In case of shortage or damage, purchaser should promptly file a claim with the delivering carrier. TRP is not liable for damage or loss of merchandise after it has left our facilities, we will however assist you in filing a claim.

RETURNS

Return requests must be made within 30 days of shipment. Return authorization is required before the items are returned for any reason. We will consider issuing a return authorization for the following reasons; manufacturing defect, order processing error, shipping error, mismarked cartons, or duplicated shipments. Returns for any other reason, and no fault of TRP, are subject to a 20% restocking charge and when authorized, must be returned freight prepaid. Return merchandise will be subject to inspection.

Any discrepancies, additional damage, signs of use, or missing parts will result in an adjustment to the amount of credit issued.

LIMITED WARRANTY

The products listed in this catalog are warranted by the manufacturers to be free from defects in materials and workmanship for a period of one year from the date of original purchase. This warranty is in lieu of all other warranties expressed or implied. This warranty covers normal use and application and does not cover damage or defect which results from alteration, accident, neglect, improper installation, operation or maintenance.

TRP International's obligation under this warranty is limited to the repair or replacement of the defective part, and in no event shall TRP be liable for reimbursement of consequential, indirect or incidental damages of any kind.

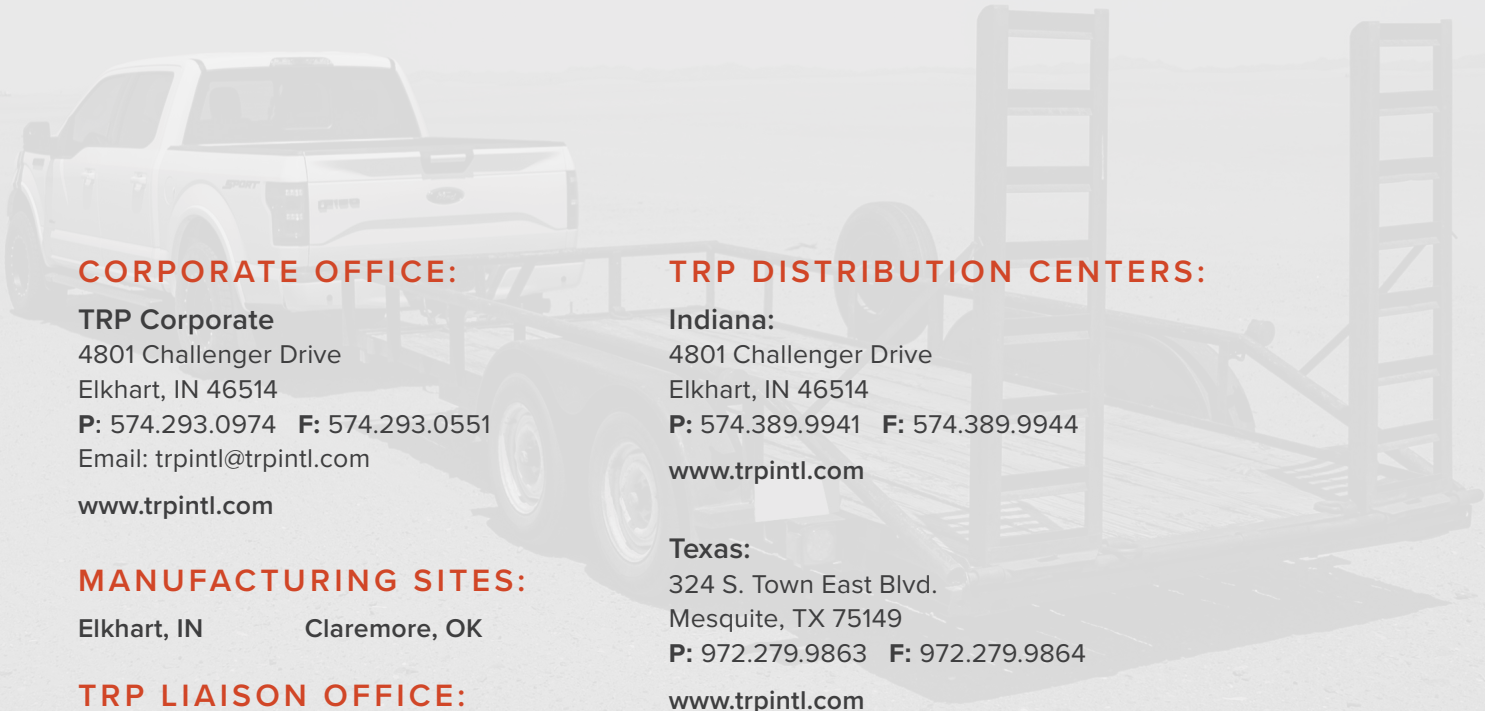
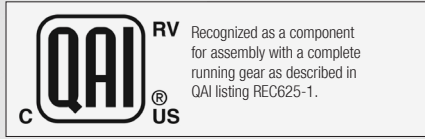

CORPORATE OFFICE:

TRP Corporate
4801 Challenger Drive
Elkhart, IN 46514
P: 574.293.0974 F: 574.293.0551
Email: trpintl@trpintl.com
www.trpintl.com

TRP DISTRIBUTION CENTERS:

Indiana:
4801 Challenger Drive
Elkhart, IN 46514
P: 574.389.9941 F: 574.389.9944
www.trpintl.com

Texas:
324 S. Town East Blvd.
Mesquite, TX 75149
P: 972.279.9863 F: 972.279.9864
www.trpintl.com

MANUFACTURING SITES:

Elkhart, IN Claremore, OK

TRP LIAISON OFFICE:

TRP China – Hefei, China
TRP Italy – Erba, Italy



SUPPLYING THE WORLD.

